

Vacuum Pump Operating Instructions

真空泵使用说明书



The high quality vacuum pump, which has high reliable, high ultimate vacuum and low noise, is regarded as the highest honor by the **VALUE**. Creating value for the customers is our core idea; satisfy customers' requirements is our research base; with this commitment to innovation, quality, and service, VALUE design a high reliable vacuum pump called "VP" for the customers all around the world.

New "VP" series vacuum pump design was a huge project. At very beginning, we positioned the product. more than 1200 questionnaire surveys has been sent to the market; then we communicated with customers whom from 30 different countries, discussed the advantages and disadvantages of the products in the market right now; furthermore, we combined the requests for the terminal customers, and finally decided to design a high reliable vacuum pump with high ultimate vacuum and low noise. From the conception to screening to the final decision, more than 10 schemes has been researched and discussed. The ABB Group (Switzerland)'s manufacturing experts, the Valeo (France)'s quality management experts, the Shell (England)'s lubricating oil experts, and our company's vacuum technology manufacturing experts jointed development completes.

In order to make sure the "VP" series pump can achieve high quality, our company imported OKUMA vertical machining center (Japan), WENZEL 3D measuring machine (Germany) to build a constant temperature and humidity assembly shop. At the same time, lean production mode was introduced to ensure the process, measurement and assembly were perfect accuracy.

"VP" series vacuum pump had a whole body structure, forced lubrication and hydraulic control system. The pump oil (special ordered from SHELL) could make sure the vacuum pump chamber with extremely high precision and good lubrication performance. The oil seal and the fluorine rubber sealing ring were imported to insure the high sealability and longer life. The Imported bearing made in Japan and the SANDVIK exhaust valve made in Swiss can guarantee 10 billion times operating life.

长久以来，**VALUE 飞越** 一直把创造卓越品质的高极限真空度、低噪音、高可靠性真空泵视为最高荣誉。秉着为客户创造价值为核心理念，把客户的需求作为我们研发的起点，怀着对高极限真空度、低噪音和高可靠性的执着追求，推出适合全球不同区域客户需求的高可靠性VP系列真空泵。

全新 VP 系列真空泵的设计是一项系统工程。

开始时，我们的团队研究产品的定位，发放了1200多份市场调查问卷，通过与全球30多个国家和区域的客户进行沟通和交流，分析了国内外产品的优点和不足，结合终端使用客户的要求，得出以高极限真空、低噪音、和高可靠性为定位点。从构思到筛选到最后定案，我们对几十个不同的方案进行了研究讨论，期间有来自ABB公司，Valeo公司以及Shell公司的电机专家、品质管理专家、制造专家，润滑油制造专家以及真空技术专家和现代工业设计团队一起执行这个项目，最终完成产品的开发。

为确保 VP 系列的制造品质达到设计品质，我们引进日本OKUMA最先进的立式加工中心，德国WENZEL三坐标测量仪器，建立了恒温、恒湿的装配车间，引进精益生产管理方式，确保从加工、测量、装配的各个环节精确无误。

VP 系列真空采用整体式泵体结构，强制油泵润滑和油压控制系统，并采用Shell为 **VALUE 飞越** 订制的高品质真空泵油确保泵腔具有极高的精度及良好的润滑性能；同时选用进口的油封和氟橡胶的密封圈，保证了各种工况下的可靠密封性和更长的使用寿命；日本进口轴承及瑞士SANDVIK材料的排气阀片均能保证100亿次的运行寿命,这一切保证 VP 系列的高极限真空度，低噪音和高可靠运行。

Table of Contents 目录

◇ Forward	◇ 前言
I Use information.....1	I 使用须知.....1
II Safety indication.....2	II 安全标志.....2
III Attentions.....2	III 注意事项.....2
IV Reception and storage.....4	IV 真空泵的接收和保管.....4
IV-1 Reception.....4	IV-1 真空泵的接收.....4
IV-2 Operating and storage environment.....4	IV-2 真空泵的运转、保管.....4
1.Description.....5	1 产品概况.....5
1.1Application.....5	1.1 用途及使用范围.....5
1.2Function.....5	1.2 结构原理.....5
1.3Technical specification.....7	1.3 泵技术参数.....8
1.4Dimension.....9	1.4 外形尺寸.....9
2.Installation.....9	2 安装.....9
2.1Transportation.....9	2.1 搬运.....9
2.2Installation site.....10	2.2 泵安装场地.....10
2.3Installation.....10	2.3 泵的安装.....10
2.4Adding oil.....10	2.4 加油.....10
2.5Working temperature.....11	2.5 泵的工作环境温度.....11
2.6Low temperature start up.....11	2.6 泵的低温启动.....11
3.Electrical Connections.....12	3 接线.....12
3.1Pump with single phase AC motor.....12	3.1 带单相电机的泵.....12
3.2Pump with three phase AC motor.....13	3.2 带三相电机的泵.....13
4.Vacuum system connection.....14	4 真空系统连接.....14
4.1 Requests for vacuum system connection.....14	4.1 真空系统连接要求.....14
5.Operation.....15	5 运转.....15
5.1Before operation.....15	5.1 运转前.....15
5.2Operation.....15	5.2 运转.....15
5.3Switching off.....16	5.3 停止运转.....16
6.Maintenance.....17	6 维护.....17
6.1 Oil checking.....17	6.1 检查泵油.....17
6.2Oil change.....18	6.2 换油.....18
6.3Oil change procedure.....19	6.3 换油的方法.....19
6.4Cleaning the dirty.....19	6.4 清洁进气口过滤网.....19
6.5Routine checking.....20	6.5 常规检查项目.....20
6.6 Trouble shooting.....21	6.6 常见故障及排除.....22

Table of Contents 目录

7.Supplied Equipment.....23	7 供货设备.....23
7.1Standard equipment.....23	7.1 标准设备.....23
7.2Accessories.....23	7.2 附件.....23
8.Warranty.....23	8 保修条款.....23
9.Spare parts.....24	9 泵易损件.....24
9.1Explode drawing.....24	9.1 泵分解图.....24
9.2Spare parts list.....25	9.2 易损件一览表.....26

Forward | Use information

- Thanks for trusting and using our products, we will try our best to supply you with good products and service.
- Please check the product received is same as you ordered and also the accessories, operating manual are attached. Please check the product if there is any damage during transportation. Contact with local distributor if the above problem is found.
- Please read the operating manual carefully before operating and use the pump according to the product operating procedures.
- We reserve the right to modify the design and specified data including operating manual without notice.
- Add vacuum oil before starting up for the first time.

! Warning

In order to prolong the usage of the vacuum pump, please read the operating manual carefully before installation, operation, repair and maintenance, which can help you to fully understand the safety, specification as well as operating procedure of the vacuum pump.

II Safety indication

Only operate VP vacuum pump in a proper way according to operating manual can ensure the safety and efficient operation of the pump. In order to enable you to fully understand the operating manual and the content of warning, we list following safety indications.

! Warning

Indicates procedures that must be strictly observed to prevent hazards to persons.

前言 | 使用须知

- 尊敬的用户，感谢您对 VALUE 飞越 的信任与支持，欢迎您使用本公司的VP系列高可靠性真空泵产品（以下简称泵），我们将竭诚为您提供优质的服务。
- 请您仔细检查收到的产品是否和订购产品一致，备附件、使用说明书等是否齐全，运输过程中是否有损坏。

如果发现上述情形请及时与本公司营业部或当地经销商联系。
- 在使用本产品前，请您务必仔细阅读此说明书，按产品操作规程进行操作。
- 产品（包括说明书）以后若有任何改动，请恕不另行通知。
- 新机使用前请务必按要求加注真空泵油。

! 警告

为确保该产品长期稳定运行，在您安装、运转、检修或保养以前，请您仔细阅读此说明书，以便充分理解有关安全方面的问题及该泵的技术参数和操作方法等相关的注意事项。

II 安全标志

只有按照本说明书正确使用，才能保证泵的安全和有效运行。为了使您能够充分理解此使用说明书及该产品上的警告标志，我们列出了各项安全标志及警告的内容。

! 警告

表示如果使用出现错误，会造成人员伤亡，危险性较大。

! Attention

Indicates procedures must be strictly observed to prevent damage or destruction of the pump.



This warning label indicates the possibility of electrical shock. Disconnect the pump from the power supply in the process of electrical connection, repair and maintenance. Make sure the proper cover of junction box before running.



This warning label indicates when opening the pump, do not touch the pump, until it has cooled.

III Attention

! Attention

Before the connection, please check the power supply is the same with the required power supply.

! Warning

Electrical connection work must only be carried out by a skilled electrician in accordance with the electrical equipment technical standard and connection regulation.

! Warning

Do not place obstacles which will influence the ventilation around the motor in order to avoid scald or fire.

! 注意

表示如果使用出现错误，可能会造成设备损伤，使设备无法正常运转或性能下降。



本警告标贴表示可能有触电的危险，在接线、维修、保养时，请先将电源切断，再进行操作。运转时请将接线盒的盖子盖住。



本警告标贴表示泵运转时及运转停止后、而整个泵的温度还很高时，请不要触摸。

III 注意事项

! 注意

使用的电源必须与产品所标识的电源相一致。

! 警告

电源连接必须由具有电工上岗证的人员按电力设备技术标准和布线规定正确操作。

! 警告

请不要在电机周围放置有碍通风的障碍物，以避免异常温升而造成烫伤或火灾等。

! Warning

The products must be grounded and the motor circuit must be equipped with a suitable rated motor protection switch before starting up.

! Attentions

The pump must be operated at ambient temperatures between 5-40°C.

! Warning

The exhaust line must be unblocked before operating. Make sure that the gas flow from the exhaust port is not blocked or restricted in any way.

! Attentions

Check the oil level before running. Do not operate the pump without oil or short of oil. Otherwise it will result in the pump failure.

! Warning

When opening the pump, do not touch the pump, until it has cooled.

! Warning

VRD series vacuum pumps shall not suitable for pumping of toxic, corrosive, flammable and explosive gas.

! Warning

VRD series pumps are strictly prohibited to operate in the explosion hazard and flammable area in case of explosion or fire.

! 警告

启动泵前，必须保证电机有效接地，并连接适当额定值的电机保护开关。

! 注意

泵的使用环境温度为5-40°C。

! 警告

泵在运行前，排气口必须保持畅通，不得以任何方式堵塞或限制排气口气流。

! 注意

泵在运转前应检查油位，不要在泵没有加油或缺油的情况下使用，否则会造成泵的失效。

! 警告

泵在长时间运转过程中或者刚刚停止运转、而泵温度还很高时，请不要触摸电机和泵，以免烫伤。

! 警告

泵严禁抽除有毒、腐蚀性及易燃易爆气体。

! 警告

泵严禁在有爆炸危险及易燃物品的场所使用，以避免引起爆炸或火灾。

! Attentions

If the medium pumped contains a small amount of dust, condensable gases, some corresponding accessory should at all events be installed. Otherwise, it will cause pump failure or deduction of performance.

! Warning

Disconnect the power supply during the repair and maintenance, in order to prevent electrical hazard.

IV Reception and storage

IV-1 Reception

Please do following inspections when you received the product:

- Whether the product is same as you ordered.
- Whether the accessories (including the first time use vacuum oil, accessories) are same as contract.
- Whether there are any damages during transportation.

If any questions, please contact with your local distributor or our sales department.

IV-2 Operating and storage environment

In order to achieve stable, reliable operation, following requirements should be satisfied during storage and operation:

- Working ambient temperature/humidity : 5—40°C. Below 85%RH
- Storage and Operating altitude < 1000m
- Storage and operating environment:
 - 1) No corrosive, flammable and explosive gases.
 - 2) The pump must be stored in a room with good ventilation.
 - 3) Avoid direct sunlight.
 - 4) Far away from heat source.
 - 5) No dust
 - 6) No frost

! 注意

抽除含少量粉尘、可凝性气体时需安装相适应的附件，否则会造成泵的失效或性能急剧下降。

! 警告

检查、修理泵时，必须切断电源再进行操作。这样可以避免触电或者泵突然启动而造成人员伤亡。

IV 真空泵的接收和保管

IV-1 真空泵的接收

在您收到产品并打开包装后，应对以下内容进行检查：

- 是否与您所订购的产品一致。
- 附件（包括可以加一次的泵油、选购件）是否按合同配备。
- 运输过程中是否造成破损。

如果有问题，请您与当地经销商或我公司营业部取得联系。

IV-2 真空泵的运转、保管环境

为使泵稳定、可靠运行，在保管、运转时必须满足以下条件：

- 运转时的温度和湿度：5—40°C，85%湿度以下
- 保管和运转，高度 < 1000m
- 保管和运转时的周围环境：
 - 1) 没有腐蚀性和易燃易爆的气体
 - 2) 必须放置在室内，且通风良好
 - 3) 避免日光直射
 - 4) 远离热源体
 - 5) 无灰尘
 - 6) 无霜

! Attentions

Do not invert the pump or subject the pump to any impact. Otherwise, the pump may be damaged.

1 Description

VP series vacuum pump is a high speed, motor direct drive, oil-sealed rotary vane vacuum pump. The pump adopts integrated cylinder structure, inner oil pump design, automatic anti-suckback valve design, oil pressure control system and adjustable gas ballast valve design.

The pumps are designed with rational structure, safety and reliability. It has high flow rate, high ultimate pressure and low noise level. The pumps are free of oil leakage and easy for maintenance. It is a highly reliable vacuum pump proved by global customers.

1.1 Purposes and scope

The VP series vacuum pump is the basic equipment in vacuum application field, especially in researching, teaching, medical field, vacuum coating.

The VP series vacuum pump can be used as the main pump for the low/medium vacuum system; also this kind of pump could be used as the backing pump for roots pump, diffusion pump, molecular pump and other ultra-high vacuum system.

1.2 Structure and principle

The VP series is double-stage direct coupled rotary-vane vacuum pump; the advantages of this pump are high reliability, low noise and high ultimate vacuum. This pump had a whole body structure, forced lubrication and hydraulic control system. At the same time, a different permeability designed gas valves made the pump maintain a high reliability in different using environment.

! 注意

请不要将泵倒置，也不要让泵体受到冲击，否则会使泵体遭受破坏。

1 产品概况

VP系列真空泵是属于高速直联（电机直接驱动）双级旋片油封（油密封）式变容真空泵。其泵体采用整体式结构设计，内置齿轮油泵设计，压力油控制的防返流阀设计，油泵压力控制系统，油液循环过滤系统，低噪音轴承及完善的润滑密封结构设计，不同掺气量的气镇阀设计，流畅的外观设计。

该泵结构设计合理，安全可靠，抽速大，极限真空度高，低噪声，不喷油，不漏油，维修方便，造型美观大方，是经全球客户验证的高可靠性真空泵。

1.1 用途及使用范围

VP系列真空泵是真空应用领域中最基本的真空获得设备，特别适用于需要获得高极限真空低噪音环境的科研、教学、实验室、分析仪器、医疗器械、真空镀膜等不同真空应用领域。

VP系列真空泵可作为中、低真空系统的主抽泵，也可以作为罗茨泵、扩散泵、分子泵等中高真空、超高真空系统的前级泵。

1.2 结构原理

VP系列真空泵为双级直联旋片式真空泵，产品以高可靠性、低噪音和高极限真空度为设计定位，通过采用世界最先进的整体式泵体结构设计，强制油泵润滑油压控制系统，同时具有不同掺气的气镇阀设计使得产品在不同使用环境中保持高可靠性。

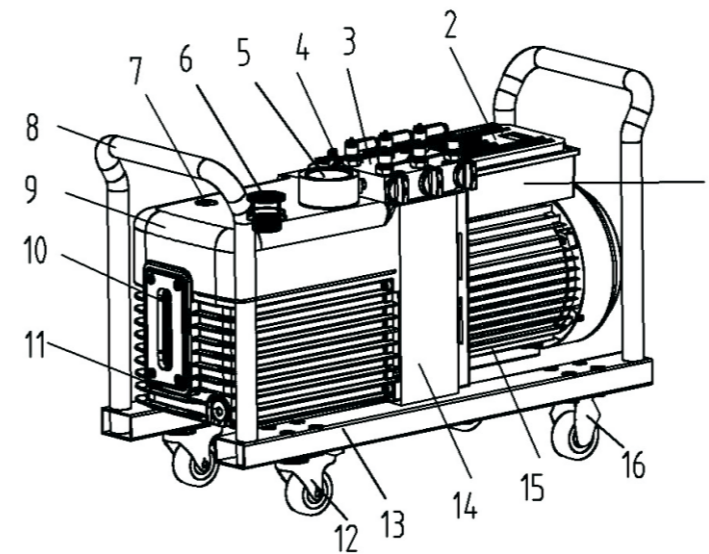

Fig.1 Outside view drawing

图1 外观图

- | | |
|----------------------|----------|
| 1.Junction box | 1. 接线盒 |
| 2.Junction box cover | 2. 接线盒盖 |
| 3.Intake valve | 3. 泵进气阀 |
| 4.Gas ballast | 4. 气镇 |
| 5.Vacuum gauge | 5. 真空表 |
| 6.Exhaust port | 6. 排气口 |
| 7.Oil fill plug | 7. 注油塞 |
| 8.handle | 8. 提手 |
| 9.Oil housing assy | 9. 油箱 |
| 10.Sight glass | 10. 油镜窗 |
| 11.Oil drain Plug | 11. 放油塞 |
| 12.Flexible casters | 12. 活动脚轮 |
| 13.Pump feet | 13. 底脚 |
| 14.Trestle | 14. 支架 |
| 15.Motor | 15. 电机 |
| 16.Fixed casters | 16. 固定脚轮 |

Refer to Fig. 2 for functional diagram:
The rotor, mounted eccentrically in the pump cylinder, has two vanes which divide the pump chamber into two different changeable compartments. When the pump rotor which was driven by the motor clockwise rotated, chamber 1 will suck air from small to big, and chamber 2 will complete the transmission of air, then chamber 3 will compress and exhaust air from big to small, and complete a work cycle from suction- compress-exhaust finally, achieve the vacuum of the system.

原理图如图2所示：泵转子偏心地安装在泵缸体内，通过两个始终紧贴缸壁的旋片把泵腔分成两个大小变化的腔体。当电机带动泵转子顺时针旋转，腔体1由小变大完成吸气，腔体3完成气体的传输，腔体3由大变小压缩排气，完成一个吸气--压缩--排气工作周期。当电机连续转动，泵体则实现不断吸气--压缩--排气，从而达到对容器抽气的目的。当排出的气体通过气道而转入另一级（低真空级），由低真空级抽走，再经低真空级压缩后排至大气中，即组成了双级泵。这时总的压缩比由两级来负担，因而提高了极限真空度。

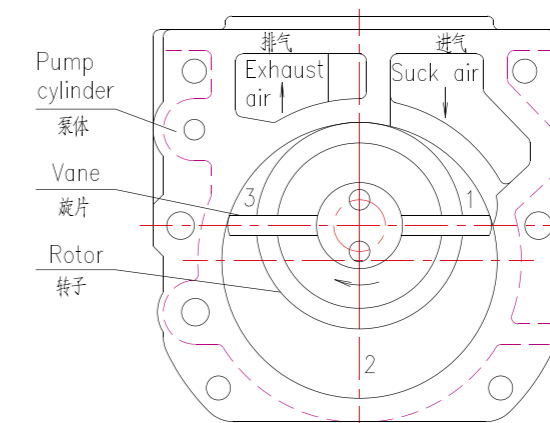

Fig.2 Functional diagram

图2 工作原理图

1.3 Pump technical specification

1.3.1 Technical Specification:

Model		VP2120	VP2200
Displacement speed (CFM)	50Hz	12	20
	60Hz	14	24
Ultimate partial pressure without gas ballast(Pa)		4×10^{-2}	4×10^{-2}
Ultimate total pressure without gas ballast(Pa)		4×10^{-1}	4×10^{-1}
Ultimate total pressure with gas ballast (Pa)		8×10^{-1}	8×10^{-1}
Power Supply		Single/3-ph	Single/3-ph
Power rating (KW)		0.75/0.55	0.75/1.1
Inlet fitting		6-7/16-20	6-7/16-20
Oil Capacity (L)		0.9~1.5	1.3~2.0
Motor speed (rpm)	50Hz	1440	1440
	60Hz	1720	1720
Ambient temperature		5-40°C	5-40°C
Noise level (dB)		≤58	≤58
Weight (kg)		36	39

Chart 1 Technical specification

1.3 泵的技术参数

1.3.1 技术参数如表1所示:

型 号		VP2120	VP2200
抽 速 (CFM)	50Hz	12	20
	60Hz	14	24
极限分压强-无气镇 (Pa)		4×10^{-2}	4×10^{-2}
极限总压强-无气镇 (Pa)		4×10^{-1}	4×10^{-1}
极限总压强-有气镇 (Pa)		8×10^{-1}	8×10^{-1}
电 源		单相/三相	单相/三相
电机功率 (KW)		0.75/0.55	0.75/1.1
进气连接口		6-7/16-20	6-7/16-20
用油量 (L)		0.9~1.5	1.3~2.0
电机转速 (rpm)	50Hz	1440	1440
	60Hz	1720	1720
工作环境温度		5-40°C	5-40°C
噪音 (dB)		≤58	≤58
重量 (kg)		36	39

表1 技术参数

1.4 Dimension 外形尺寸

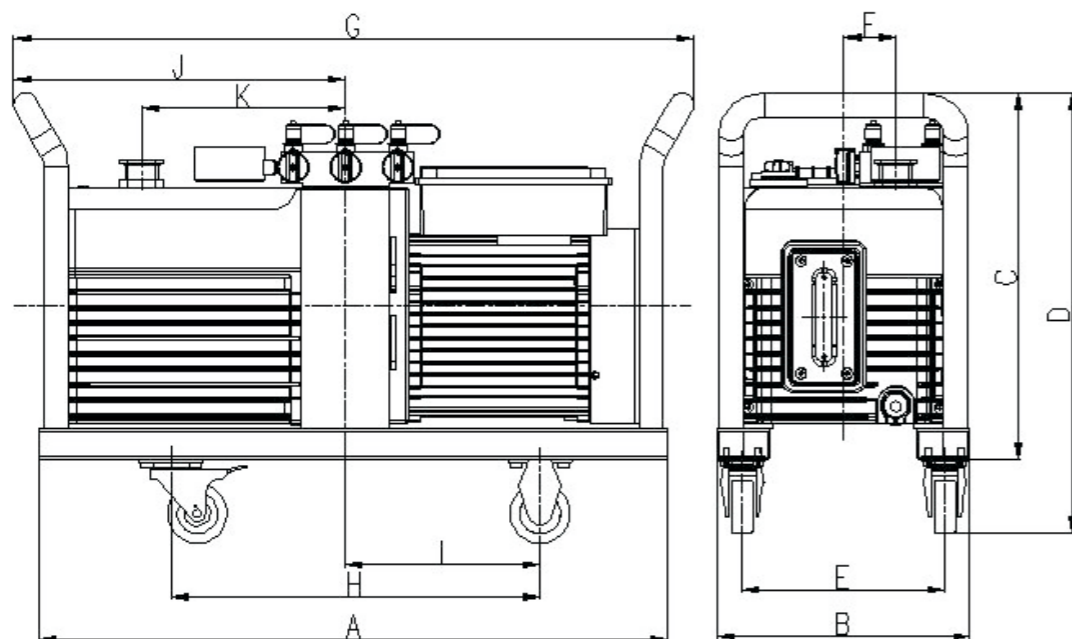

The dremension for VRD series pump		VRD 系列直联旋片式真空泵外形及尺寸										
TYPE	A	B	C	D	E	F	G	H	I	J	K	DN
VP2120	570	240	335	405	182	59	626	394	205	301	165	7/16-20
VP2200	570	240	335	405	182	59	626	394	205	301	185	7/16-20

Fig. 3 pump dimension 图3 外形尺寸图

2 Installation

2.1 Transportation

Any negligence will cause pump damage. Take care during transportation.

! Warning

Pump must only be moved when stopped and supply switched off.

! Warning

Check the pump for the presence of any oil leakage, Since there exists the danger that someone may slip on spilt oil.

2 安装

2.1 搬运

搬运过程中任何一个小的疏忽都可能造成泵的损伤，请小心搬运。

! 警告

泵只有当停止运转，且断开电源后方可移动。

! 警告

由于流出的油有使人滑倒的危险，请检查泵是否漏油。

! Warning

When lifting the pump you must make use of the hook provided on the pump.

2.2 Installation site

When choosing the pump installation site, please consider the followings:

- Suitable for installing, maintenance and disassembly
- Good ventilation
- Convenient for electrical connecting

! Warning

VRD K series pumps are strictly prohibited to operate in the explosion hazard and flammable area in case of explosion or fire.

! Warning

Do not place obstacles which will influence the ventilation around the motor in order to avoid scald and fire.

2.3 Installation

When connect the pump to vacuum system, please place the pump horizontally (12/ Fig. 1, 16/ Fig. 1), or you can unload the rubber feet (11/ Fig. 1), connect it by feet-hole screw.

! Attentions

Oblique installation may result in pump's vibration, high noise or even damage. The pump should be set up on a flat and firm surface.

2.4 Adding oil

Open the oil fill plug (7/ Fig. 1), add the oil according to the technical data. Add oil to recommended oil level for the first time.

! 警告

当吊起泵时必须使用泵上的吊环螺钉，使用前请确认吊环螺钉是否旋紧。

2.2 泵安装场地

泵安装场地选择应考虑：

- 方便安装、维护、拆卸等作业；
- 良好的通风条件；
- 方便接线。

! 警告

泵严禁在有爆炸危险及易燃物品的场所使用，以避免引起爆炸或火灾。

! 警告

请不要在电机周围放置有碍通风的障碍物，以免异常升温而造成烫伤或火灾等。

2.3 泵的安装

泵连接到真空系统时，可直接将脚轮(12/图1, 16/图1)水平放置于地面上。

! 注意

如果将泵倾斜安装，可能会造成泵的振动、噪声加大，甚至损坏。请将泵水平安装在平稳，牢固的地方。

2.4 加油

拧开注油塞(7/图1)，按要求加注泵油，第一次加油时应加至油位上限MAX 80%处。

It is VPO series recommended to use VALUE company's high speed vacuum oil . It may cause unstable performance of vacuum pump and influence the vacuum pump lifespan if using other vacuum oil.

During the operation, the oil level of the pump must always be visible between the Max to Min mark. Oil at VALUE recommended level is better. Excessive or insufficient oil will decrease the pump performance or even cause malfunction of the pump.

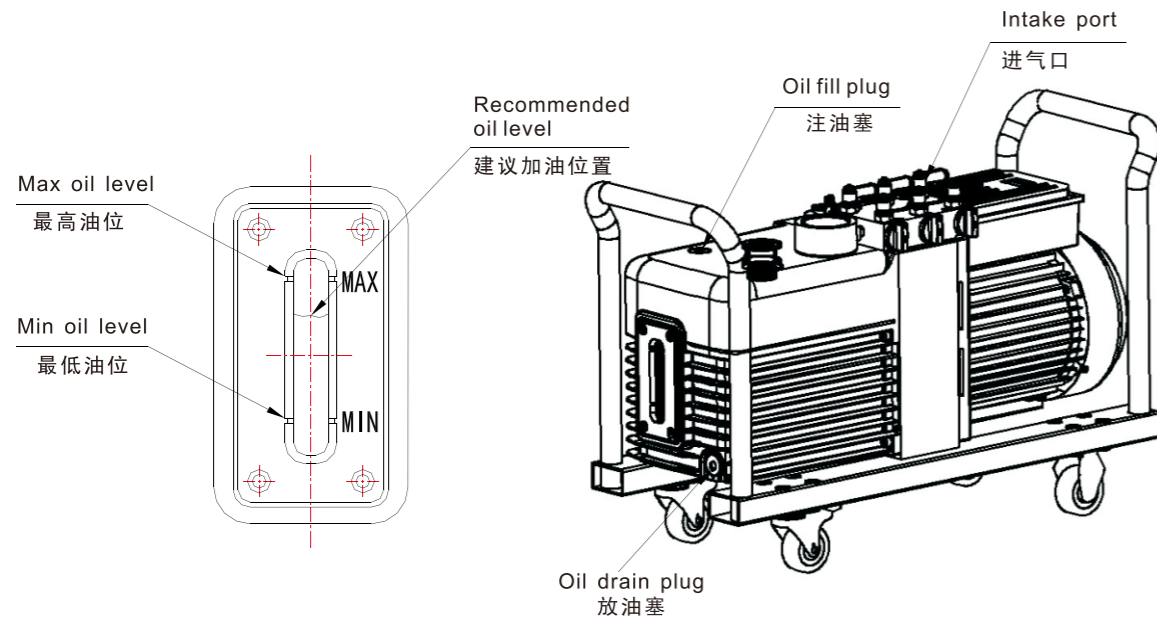

Fig. 4 Add oil diagram

建议用户使用VALUE飞越公司VPO系列高速直联泵专用油。如果使用其它泵油，可能会导致泵的工作性能不稳定，影响泵的工作寿命。

泵运转过程中，请将真空泵的油面控制在油位视窗的MIN---MAX之间范围内，液面高度在80%上下为佳。如果油量过多或不足，泵的性能就会下降，甚至还可能出现故障。

图4 加油示意图

! Attentions

The pump must be switched off and exhaust must be unbleeked before topping up any oil.

2.5 Working ambient temperature

Pump's working ambient temperature: 5~40°C, humidity < 85%

2.6 Low temperature start up

For single-phase power source, the minimum starting temperature is 10 °C, For three-phase power source, the minimum starting temperature is 5 °C.

! 注意

注油前必须停泵,且排气口不能堵塞,以防止注油时油从加油口溢出

2.5 泵的工作环境温度

泵的工作环境温度为5~40°C, 湿度不大于85%。

2.6 泵的低温启动

单相电源泵的最低启动温度为10°C,三相电源泵的最低启动温度为5°C。

3 Electrical connections

! Warning

Before the connection, please check the power supply is the same with the required power supply.

! Warning

Electrical connection work must only be carried out by a skilled electrician in accordance with the electrical equipment technical standard and connection regulation. Wrong connection may lead to safety accident.

3.1 Pump with single phase motor

With single phase design, power supply cable, switch, overload protector are all connected. The direction of rotation need not be checked as it is fixed. The pump can be directly connected by means of the connection cable and plug to the single phase power supply. The motor is protected against overloading by a thermal overload protector.

! Warning

If the thermal overload protector shuts off the pump, if you want pump continue to work, you should button and than swith on. The plug should be disconnected from the power supply before starting with any work on the pump.

3 接线

! 警告

在连接电源之前，请您检查电源与产品铭牌上规定的电源是否一致。

! 警告

接线时必须由熟练的电工按电力设备技术标准 and 布线规定正确操作，错误的布线可能引起安全事故。

3.1 带单相电机的泵

VP 系列带单相电机的泵，其电源线、开关、保护器已连接好，泵的转向固定，不需要检查，直接插上单相电源即可运行。电机过载有过热开关保护。

! 警告

如果电机热保开关动作电机将停止工作，如需泵继续工作，需关掉电源后待电机冷却，再打开电源，泵就会恢复运转。在对泵的任何操作之前，必须切断电源。

3.2 Pump with three-phase motor

3.2.1 Pump with three-phase motor electrical connection

When connecting three-phase motor pump, please open the junction box cover (2/ Fig. 1) connect the pump according to Fig. 7. The pump is supplied without any accessories of electrical connection. You must connect the pump using an appropriately rated cable and a suitably rated motor protection switch. The value set on the motor protection switch must correspond to the current rating stated on the nameplate of the motor.

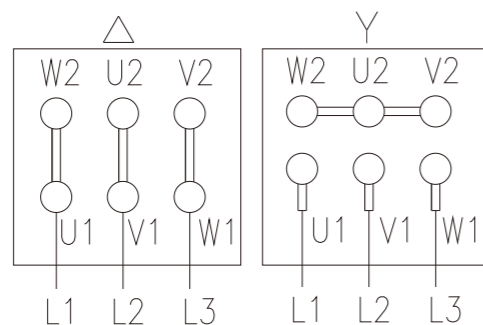

Fig.5 Three-phase motor connection

3.2.2 Pump with three-phase motor direction

Check whether the motor rotate direction is same as motor arrowhead. Please cut off the power immediately and interchange two phases of the connection (any 2 from W1, U1, V1) if the motor rotate direction is not same as the motor

3.2带三相电机的泵

3.2.1 三相电机接线方法

VP系列带三相电机的泵，接线时请打开接线盒盖（2/图1），按图7所示连接，随机不带电气连接附件，选用的电缆及电机保护开关的额定电流值必须与电机铭牌上的额定电流值相匹配。

图5 三相电机接线方法

3.2.2 三相电机转向

观察电机的转向是否与电机箭头方向一致；如果电机转向相反，立即切断电源，并交换任意两根相线（W1、U1、V1中任意2个）将电机转向纠正。

3.2.3 电机转向确定方法

打开进气口（3/图1），排气口（6/图1），用一张薄纸条放在排气口正上方50mm处，再短暂接通电源，若薄纸条向上远离排气口方向飘动，表明电机转向正确。电机上所示的箭头方向即为泵的转向。

! Attentions

If the pump runs for too long in the wrong direction, it may cause the damage of pump parts.

4. Vacuum system connection

Connection between pump and vacuum system is international standard flange, it's easy to operate.

4.1 Requests for vacuum system connection

- Between vacuum pump and vacuum system, the connecting lines should be as short as possible, and reduce the corner
- Make sure the DN of connecting line between vacuum pump and vacuum system should be same as intake port. Check the inlet port filter regularly and keep its cleanness.
- Make sure the DN of exhaust fitting should be same as intake port. The exhaust line should preferably be installed with a downward slope so as to prevent condensate from flowing back into the pump and contaminating the oil. Please periodically drain the condensed oil in the exhaust pipe for avoiding of exhaust pipe block. If the exhaust line has an upward slope, a condensate trap must at all events be installed.
- Leak check the connection between pipe and flange. Vacuum-tight connection of the pump is essential so that the pump can attain the ultimate vacuum .

! Warning

On no account may the pump be operated with a blocked or constricted exhaust line. Make sure before start-up that any blinds or similar shut-off devices in the exhaust line on the pressure side are opened and that the exhaust lines are not obstructed by deposits.

! 注意

如泵在错误的转向下运转过长时间，会造成泵内零件的损坏。

4. 真空系统连接

泵与真空系统连接采用国际标准“快卸法兰”，方便快捷。

4.1 真空系统连接要求

- 连接泵与真空系统的管道应尽可能短。
- 连接泵与真空系统的管道口径应尽可能和进气口口径一致。应定期检查进气口的过滤网，保持清洁。
- 泵排气口连接管道口径应尽可能和排气口口径一致。排气管道安装时应坡度向下，以防止凝物流回泵中而污染油，并注意定期放出排气管道中长期积聚的油，以防排气管道堵塞。如排气管道坡度向上，则必须安装凝聚物捕集器。
- 对管道和法兰的连接处进行检漏。良好的真空密闭性对于泵达到极限压力至为重要。

! 警告

千万不要使用阻塞的或狭窄的排气管道，要确保在泵启动前排气管道没有被沉积物阻塞。

5 Operating

5.1 Before operating

- The exhaust line must be unblocked. On no account may the pump be operated with a blocked exhaust line.
- The oil capacity in the housing should be suitable.
- Running direction of the motor as requested.
- Well grounded for the motor .
- Check the power supply and ensures it matches the specifications on the pump.

5.2 Operating

5.2.1 Vacuum system without condensable gases

In the presence of permanent gases, the gas ballast valve knob (4/ Fig.1) should be switched off (as Fig.6 gas ballast valve knob arrow C below). It may cause the rise of

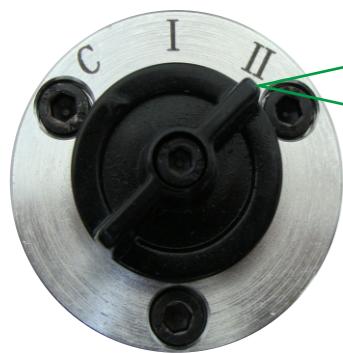

Fig. 6 Gas ballast valve knob

5.2.2 Vacuum system with condensable gases

- When the vacuum system contains a small amount of condensable gas, open the gas ballast valve (refer to Fig 6. gas ballast valve arrow I or II), It can pump a small amount of condensable gas effectively. Close the gas ballast valve when the vacuum system pressure reduced to a certain value.

5 运转

5.1 运转前

- 泵的排气口必须畅通，不得在封堵排气口情况下启动泵。
- 油箱内注油量是否合适。
- 电机转向是否符合要求。
- 电机是否有效接地。
- 电机所接电源是否与铭牌上的电压及频率相一致。

5.2 运转

5.2.1真空系统无可凝性气体

抽除永久性气体时，气镇（4/图1）阀旋钮应处于关闭状态（如图6气镇旋钮箭头指向C）。如果打开气镇（4/图1），就会造成极限压力上升（真空度降低）的现象。

Gas ballast valve knob arrow
气镇旋钮指向

图6 气镇阀旋钮

5.2.2 真空系统含有可凝性气体

- 当真空系统中含有少量的可凝性气体时，打开气镇阀（如图6气镇旋钮箭头指向 I 或 II），可抽除真空系统中少量的可凝性气体，待真空系统压力降低到一定数值时，再关闭气镇阀进行正常抽气。

- If the pump is operated in low temperature, condensable gas may be dissolved in the oil of the pump. This impairs the properties of the oil and there is the risk of corrosion within the pump. For this reason the pump must not be switched off immediately after termination of the process. The pump must remain on with the gas ballast valve open and the intake line sealed until all gases which were dissolved in the oil has been removed. We strongly recommend that VRD pump be left running for about 30 minutes after termination of the process.

5.2.3 Function of Pump Intake Valve

This intake valve can be simultaneously connected with 6pcs devices. Each intake port work independently without any mutual interference.

! Warning

During the operation and termination after one hour, the pump surface temperature will be very high. Do not touch the motor and pump in case of scald

! Attentions

We recommend operation of the pump with gas ballast valve open if pumping a small amount of condensable gases.

5.3 Switching off

5.3.1 Switching off the pump normally

Finish pumping under normal circumstances, the pump can be switched off directly. The air intakes can be switched off automatically by the inner anti-suckback valve, thereby keep the cleanness of the system .

5.3.2 Putting the pump out of operation

- If the pump was stopped using for a long time, please cover the inlet and exhaust port, in case of the dust may pollute the pump.

- 如果泵工作在较低的温度下，可凝性气体可能溶解于油中，泵油可能变质，从而影响泵的性能，还可能腐蚀泵体。因此在抽气过程终止后不要立即停泵，必须使泵在气镇阀打开和进气口关闭的情况下继续运转，直至溶解在泵油中可凝性气体充分分离出去为止。如果抽含有少量可凝性成分的气体，建议在运行泵时，将气镇阀打开。

5.2.3 泵进气阀功能

进气阀可以同时连接6台设备，且每个接口都能独立工作，互不干扰。

! 警告

泵在运行时及停泵后1小时内，泵的表面温度可能会很高，严禁接触电机和泵表面，以免接触时造成烫伤。

! 注意

我们建议当抽取少量可凝气体时，打开气镇阀。

5.3 停泵

5.3.1正常情况停泵

泵在正常情况下工作完成后，可直接停泵。内置自动防返油阀，可在停泵时自动将进气口截止，防止返油，保证真空室清洁。

5.3.2 泵长期停用

- 长时间不用泵时应盖住进气口和排气口，避免灰尘污物污染泵体。

■ Gas will be dissolved in the pump oil when putting the pump out of operation for long. It is recommended to let the pump continue to operate for 30 minutes with the intake line (3/Fig.1) closed and the gas ballast valve (4/Fig.1) open. The pump can resume normal use after the pump be degassed.

■ 长时间不用泵时气体会吸附在油中，再次使用泵时可将泵在进气口（3/图1）关闭与气镇阀（4/图1）开启的情况下运转约30分钟，将被吸附的气体除去后即可恢复泵的正常使用的。

6 Maintenance

! Warning

Disconnect the power supply before repairing. It's forbidden to connect the power supply during repairing. Otherwise, the risk of injury may occur.

! 警告

检查前请务必切断电源，检查过程中也不能接通电源，否则有受伤危险。

! Warning

Pump temperature is very high when the pump just stopped. Do all the checking when the pump is cooled down to avoid the scald.

! 警告

泵刚停止时，泵温很高，因此一定要在泵温完全降下来以后再进行检查，以免造成烫伤。

6.1 Oil checking

Please use clean and appropriate oil to ensure the pump performance and life. Arrange for the frequency of changing oil as your different operation situation. Check the oil regularly.

6.1 检查泵油

为确保泵的性能和寿命，必须确保使用清洁干净及适量的泵油；泵油更换周期随泵的工况不同而异，必须做到定期检查。

6.1.1 Checking the oil level

During the operation the oil level of the pump must always be visible between the Max to Min mark (refer to Fig.4). Add oil if the oil level is lower than Min mark and discharge oil if the oil level is higher than Max mark. Liquid height at recommended level is the best.

6.1.1油位检查

泵工作时，泵油液面应始终保持在最低油位线和最高油位线之间（见图4），若液面高度低于最低油位线应及时加油。若液面高度高于最高油位线，应拧开放油塞（11/图1）放出多余的泵油。

6.1.2 Checking the oil quality

Normally the oil is clear and transparent. If the oil darkens, it should be changed.

6.1.2油品检查

观察泵油颜色，正常泵油是清洁和透明的；若泵油颜色变暗或浑浊时需要换油。

6.2 Oil change

- Change the oil in time if the oil contains mass liquid, organic solvents or corrosive gases
- Change the oil if the pressure declines as time by.
- Oil should be changed after the first 100 operating hours for the first usage.
- Add oil if the pump is operated under hyper-3000pa higher pressure for long time
- It is recommended to change the oil every 2000 operating hours .

6.2 换油

- 如果泵吸入大量水份、有机溶剂或腐蚀性气体，需及时换油。
- 泵的真空度随运行时间不断下降，需及时换油。
- 新泵初次使用，第一次换油时间建议在泵运行100小时后进行。
- 如果泵在高于3000Pa的高压力下长时间运行，泵油消耗较大，注意及时补充泵油。
- 在低压下抽除清洁气体时，建议每2000小时左右更换一次油。

! Warning

If there is the danger that the operating agent may present a hazard in any way due to decomposition of the oil, or because of the media which have been pumped, you must determine the kind of hazard and ensure that all necessary safety precautions are taken.

! 警告

由于油的分解或已抽进的介质，使工作油中存在危害性物质，必须确定危害的性质，并采取一切必要的安全预防措施。

! Warning

In the case of hazardous substances determine the kind of hazard first and observe the applicable safety regulations. If the potential hazard still persists, the pump must be decontaminated before starting with any maintenance work.

! 警告

当存在危害性物质的情况下，首先确定危害的性质，并遵守适合的安全规程。如潜在的危险仍继续存在，在任何维护工作开始前，必须将泵进行去污染处理。

! Warning

Never exchange the oil while the pump temperature is still high. Exchange the oil when the pump cooled down to lower than 50°C . You must wear suitable protective clothing.

! 警告

切勿在泵温较高的情况下换油，必须等泵冷却到低于50°C的温度时方可换油，并穿戴合适的防护服。

! Attentions

We can only guarantee that the pump operates as specified by the technical data by using VALUE VPO series high vacuum pump oil.

! 注意

只有使用VALUE飞越公司VPO系列高速直联泵专用油，才能保证泵的可靠运行，达到规定的性能指标。

6.3 Oil change procedure

- Remove the oil drain plug (11/Fig.1) and let the used oil drain into a suitable receptacle. When the flow of oil stops, screw the oil drain plug back in, briefly switch on the pump(max. 10s) and switch it off. Remove the oil-drain plug again and drain off the remaining oil. It can remove the residual oil from the pump chamber.
- Screw the oil-drain plug back in (check the O ring and replace it if necessary)
- Remove the oil filling plug back in (7/Fig.1), and fill fresh oil. (Please refer 2.4 adding oil)

! Warning

Always carry out the oil change when the pump is switched off and cooled down.

6.4 Cleaning the dirt trap

During the process of dirt trap, some dust, grease will be adsorbed and piled up, which resulting the reduction of the pumping speed, and even obstructive. At the meantime, dirt entering into the pump body chamber and results heavy wear and tear. Clean the dirt trap regularly as your different operate situation. If cleaning is needed, Remove the dirt trap and clean with a cleaning agent, blow it out with compressed air and then re-install. Replace the defective dirt trap if necessary.

6.3 换油的方法

- 换油时打开放油塞（11/图1），将用过的油排放到适当的容器中。当油流动停止时，再拧上放油塞。短暂的开动泵（约10秒），使泵腔内的剩余油排出，再断开电源，再次打开放油塞，放空剩余的油。
- 将放油塞拧上(检查O型圈，如损坏则更换)。
- 拧开注油塞（7/图1），注入新油（参照2.4加油）。

! 警告

必须在泵断开电源和泵及电机的温度都不高的时候换油。

6.4 清洁进气口过滤网

过滤网在使用过程中，由于粉尘、油垢等污物会吸附和堆积在过滤网上，造成抽速下降，甚至阻塞；同时污物进入泵腔使泵体磨损加剧；视使用工况不同需定期检查过滤网。若过滤网需要清洗时，将过滤网取出清洗干净，吹干后重新安装；如有损坏需更换。

6.5 Routine checking

	Inspection	Testing	Period	Remarks
1	Oil level	Eyeballing oil level	Every Three Days	Add oil if the oil level is low Refer to Section 2.4 drawing6
2	Oil color	Eyeballing the oil color in the oil sight level	Every Three Days	Normally the oil is clear and transparent . If the oil darkens , it should be changed . Refer to section 6.3
3	Pump noise	Whether the noise is normal	Every three days	Refer to 6.6 if the noise level is abnormal
4	Pump vibration	Whether there is any abnormal vibration	Every Three Days	Check whether any pump feet , feet screws loosen
5	Pump temperature	Temperature measuring meter	Every one week	Check the fan of the pump and motor for deposits and clean as required .
6	Seal & O ring	Eyeballing	Every one month	Change it as required
7	Dirt trap	Check whether any foreign matter enters	Every one month	Clean the sirt rtap and blow it out with compressed air

Table 2 Routine Checking

6.5常规检查项目见表2:

	检查内容	操作测试	维护周期	备注
1	检查油位	目测检查观察油位	每三天一次	当油位下降时，请再加油，参见2.4节图6
2	检查泵油颜色	目测检查，观察窗处泵油颜色是否异常	每三天一次	正常的油是清洁透明的，如果油色发暗则应换油，换油方法参见6.3
3	检查泵的声音	声音是否异常	每三天一次	当声音出现异常，噪音增大时请参看6.6故障列表
4	检查泵的振动	振动是否过大	每三天一次	请检查泵脚、地脚螺钉是否松动
5	检查泵的温度	温升是否异常	每周一次	请检查泵及电机的风扇有无沉积物，如果有请清洁。
6	检查是否漏油	目测检查	每月一次	拆装检查
7	检查进气口过滤网	检查是否有杂物	每月一次	清洁杂物并用压缩空气吹干

表2 常规检查表

6.6 Trouble shooting

Fault	Possible reason	Solusion
Pump can not be started	<ol style="list-style-type: none"> 1.Out of electrical 2.Operation voltage is abnormal 3.Motor is malfunctioning 4.Overload protector start up 5.Oil temperature is below 10°C 6. Pump is jammed 7. Out of operation for long , liquid and organic solvents result rust of the pump body 8. Pump inner accessories are damaged 	<ol style="list-style-type: none"> 1.Check the connection of power supply , switch 2.Voltage wave within $\pm 10\%$ 3.Replace the motor 4.Press the overload protector 5.Heat the pump and pump oil 6.Repair the pump 7. Repair the pump 8. Repair the pump
Pump can not reach to the maximum pressure	<ol style="list-style-type: none"> 1.Pump is too small 2.Vacuum system leak 3.Measuring technique or gauge is unsuitable 4.Vacuum gauge not correct 5.Oil level is too low 6. Oil is unsuitable or deteriorated 7. Lubricate seal oil channel insidepump blocked 8. Intake line is dirty 9.Exhaust valve is malfunctioning 	<ol style="list-style-type: none"> 1.Replace the pump 2.Check the leakage 3.Use correct measuring technique and gauge . Measure the pressure directly at pump's intake port 4.Chose suitable vacuum gauge. 5.Add oil 6.Change oil 7. Clean oil channel 8. Clean the vacuum lines. 9.Repair the valve.
Pumping speed is too low	<ol style="list-style-type: none"> 1.Intake port channel is clogged 2.Connecting lines are too narrow or too long 3.Exhaust port channel is cloggedunsuitable 4.Exhaust filter is clogged 	<ol style="list-style-type: none"> 1.Clean the intake port channel 2.Use adequately wide and short connecting lines . 3.Keep the exhaust port channel free 4.Clean or change the exhaust filter
Abnormal voice	<ol style="list-style-type: none"> 1.Abnormal input power supply 2.Motor is malfunction 3.Foreign body into the pump 4.Oil level is too low 5. Coupling element is worn 6. Pump inner accessories are damaged. 	<ol style="list-style-type: none"> 1.Check the connection of power supply , switch 2.Voltage wave within $\pm 10\%$ 3.Clean the pump body 4.Add oil 5. Install new coupling element 6. Repair or chang the accessories
Higher temperature than normal	<ol style="list-style-type: none"> 1.Continuous operation under high pressure in the intake port 2.Oil level is too low 3.Process gas is too hot 4.Cooling air supply is obstructed 5. Pump fan is malfunction 6. Oil cycle is obstructed 7. Ambient temperature is too high 	<ol style="list-style-type: none"> 1.Shorten exhaust time as far as possible 2.Add oil 3.Set pump up correctly . 4.Set pump up correctly. 5. Change the pump fan 6. Clean and repair the oil lines and channels . 7. Reduce the ambient temperature
Oil in the intake line or in vacuum vessel	<ol style="list-style-type: none"> 1.Oil comes from the vacuum system 2.Anti-suckback valve spring is obstructed 3.Anti-suckback valve board is obstructed 4.Oil level is too high 	<ol style="list-style-type: none"> 1.Check the vacuum system 2.Change the anti-suckback valve spring 3.Change the anti-suckback valve board 4.Drain the excess oil
After switching the pump , pressure in system rises too fast	<ol style="list-style-type: none"> 1.System has a leak 2.Anti-suckback valve is malfunctioning 	<ol style="list-style-type: none"> 1.Check the vacuum system 2.Repair the anti-suckback valve
Too much oil in the exhaust port	<ol style="list-style-type: none"> 1.Too much oil in the pump 2.Continuous operation under high pressure in the intake port 	<ol style="list-style-type: none"> 1.Drain some oil 2.Shorten exhaust time as far as possible
Oil seal leak	<ol style="list-style-type: none"> 1.Oil seal broken , oil leak 2.Seal ring was deformed , oil leak 	<ol style="list-style-type: none"> 1.Replace new oil seal 2.Replace new seal ring

Table 3 Trouble shooting

6.6常见故障及排除见表3

故障	引起故障原因	排除故障办法
泵无法启动	<ol style="list-style-type: none"> 1. 电源不通 2. 输入电源电压异常 3. 电机发生故障 4. 过载保护器保护启动 5. 泵油温度低于10°C 6. 泵内有异物引起卡机 7. 停泵时间太长，吸入水分、有机溶剂使泵体生锈 8. 泵体内部零件破损 	<ol style="list-style-type: none"> 1. 检查电源，开关，线路连接情况 2. 确保电压波动在额定电压的$\pm 10\%$以内 3. 更换电机 4. 检查工作温度，降低环境温度或被抽气体温度 5. 提高环境温度 6. 维修泵 7. 维修泵 8. 维修泵
泵达不到极限压强	<ol style="list-style-type: none"> 1. 真空系统配置不合理，泵太小 2. 真空系统泄漏 3. 测量方法或规管不合适 4. 真空计不准或不合适 5. 泵体内油位太低 6. 泵油不合适或变质 7. 泵体内润滑密封油路阻塞 8. 进气口被污染 9. 排气阀故障 	<ol style="list-style-type: none"> 1. 重新选择合适的泵 2. 检漏补漏 3. 使用正确的测量方法及规管在泵的进气口处直接测量真空度 4. 选择合适的真空计 5. 加入规定油量 6. 更换符合质量要求的新油 7. 拆卸修理、清洁油路 8. 清洗抽气管道 9. 维修排气阀
泵的抽速太慢	<ol style="list-style-type: none"> 1. 进气口管道阻塞 2. 进气管道过小或管道过长 3. 排气口管道不畅 4. 排气过滤网被堵塞 	<ol style="list-style-type: none"> 1. 清洗进气口管道 2. 尽可能用短粗的进气管道 3. 保持排气口管道畅通 4. 清洗或更换排气过滤网
泵声音异常	<ol style="list-style-type: none"> 1. 输入电源电压异常 2. 电机不良 3. 泵内进入异物 4. 泵体内油位太低 5. 弹性联轴器破损 6. 泵体内部零件破损 	<ol style="list-style-type: none"> 1. 检查电源，开关，线路连接情况 2. 确保电压波动在额定电压的$\pm 10\%$以内 3. 拆卸修理、清除异物 4. 加入规定油量 5. 更换弹性联轴器 6. 拆卸修理、更换零件
泵温过高	<ol style="list-style-type: none"> 1. 进气口高压下连续运行 2. 泵体内油位太低 3. 被抽气体温度太高 4. 安装通风不良 5. 泵风叶损坏 6. 泵体内循环油路不畅 7. 环境温度太高 	<ol style="list-style-type: none"> 1. 尽可能缩短排大气时间 2. 加入规定油量 3. 在进气口加冷阱等 4. 改善通风环境 5. 更换泵风叶 6. 拆卸修理、清洁油路 7. 降低环境温度
在泵进气管道中有泵油	<ol style="list-style-type: none"> 1. 油来自真空系统 2. 防返流阀弹簧失效 3. 防返流阀板损坏 4. 油径过高 	<ol style="list-style-type: none"> 1. 检查真空系统 2. 更换防返流阀弹簧 3. 更换防返流阀板 4. 放掉多余的泵油
停泵后真空系统压力升高过快	<ol style="list-style-type: none"> 1. 真空系统泄漏 2. 防返流阀失效 	<ol style="list-style-type: none"> 1. 对真空系统进行检查、补漏 2. 维修防返流阀
排气口喷油过多	<ol style="list-style-type: none"> 1. 泵内加油过多 2. 进气口高压下连续运行 	<ol style="list-style-type: none"> 1. 放出多余泵油 2. 尽可能缩短排大气时间
密封面漏油	<ol style="list-style-type: none"> 1. 油封磨损、损坏漏油 2. 密封圈变形、损坏漏油 	<ol style="list-style-type: none"> 1. 更换新的油封 2. 更换新的密封圈

表3 故障检查表

7. Supplied Equipment

7.1 Standard equipment

Upon delivery, the small-flange connection ports of the pump are blanked off. Two flanges, two centering rings and two clamping rings each(KF25/KF40)are supplied as standard equipment to connect the intake and discharge lines. One 25KF/40KF, centering ring is including a dirt trap sieve for the intake port.

7.1.1 Pump with single-phase AC Motor

The pump is supplied with motor, switch, mains cable, plug.

7.1.2 Pump with three-phase AC motor

The pump is supplied with motor and crane eye.

A switch, mains cable and plug are not part of the standard equipment.

7.2 Accessories

- Other in/exhaust interface
- Dust filter
- Oil mist filter

Remarks: All accessories are optional parts , Any other requests about accessories , please contact us

8. Warranty

- VP series vacuum pump has a one year guarantee from the buying date.
- Our company will provide maintenance service free of charge in the period of guarantee provided on the normal use according to the operating manual.
- In case of following failures, repair fare is needed.
 - 1) Malfunction by nature disasters or artificial factor
 - 2) Malfunction under special usage.

7. 供货设备

7.1标准设备附件:

交货时, 泵的快卸法兰接口是封闭的, 标准设备供货时带有2个法兰、2片橡胶隔膜、2个肩环和2个卡箍 (KF25或KF40), 其中进气口肩环上带有粉尘过滤网。

7.1.1带单相交流电机的泵

泵供货时包括电机、开关、电源电缆、插头和吊环。

7.1.2带三相交流电机的泵

泵供货时包括电机和吊环。

标准设备不包括开关、电源电缆和插头。

7.2附件

- 其它型式进/排气接口
- 粉尘过滤器
- 油雾过滤器

注: 附件为选购件, 如果您对附件有其他要求, 请与我们联系。

8. 保修条款

- VP 系列真空泵的保修期为自购入起一年整。
- 在保修期内, 按使用说明书要求的正常使用条件下发生的故障, 本公司将无偿提供维修服务。
- 属以下情况引起的故障, 本公司需进行有偿修理:
 - 1) 受自然灾害或人为因素引起的故障。
 - 2) 特殊使用环境造成的故障。:

3)Malfunction of damageable spare parts (refer to table 2)

Malfunction by non- normal operation or error use which is identified by our technical engineer

3) 易损件 (见表2) 的损坏。

经本公司技术人员鉴定, 为非正常操作或使用不当引起的故障。

9. Spare parts 泵易损件

9.1 Exploded drawing 泵分解图如图8所示:

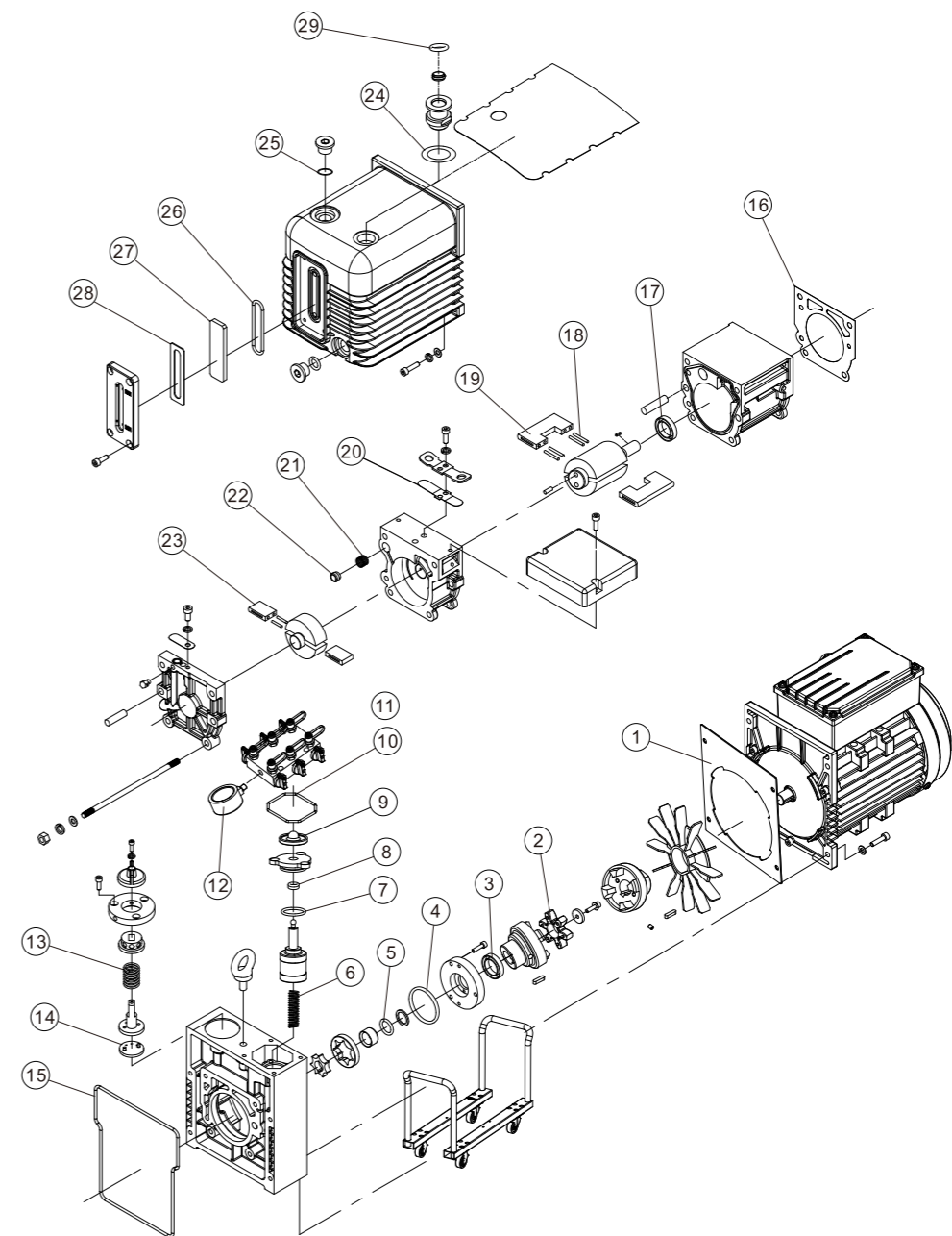

Fig.7 Exploded drawing

图 7

9.2 Spare parts list

NO.	Item	Item	Code	Position	Qty
			VP2100、VP2200		
1	Washer	Card board	320220101	Motor	1
2	Spider	Rubber	320050101 (3-Phase)	Coupling	1
2	Spider	Rubber	320050102 (1-Phase)	Coupling	1
3	Seal	FKM	300281601	Oil pump cover	1
4	O ring	FKM	300310072	Front stator	1
5	O ring	FKM	300310137	Front rotor	1
6	Spring	SUS	320110205	Trestle	1
7	O ring	FKM	300310074	Anti-suckback cover	1
8	Seal	FKM	300280902	Anti-suckback cover	1
9	Valve	FKM	320510101	Anti-suckback piston	1
10	O ring	FKM	300310073	Intake port	1
11	Control Valve ASSY	/	320340102	Intake port	1
12	Vacuum Gauge	/	KF25:300310070	/	2
13	Spring	SUS	320110302	Gas ballast	1
14	Washer	FKM	320230101	Gas ballast	1
15	O ring	FKM	300310079	Trestle	1
16	Gasket	Paper	320210101	Front chanter	1
17	Seal	FKM	300280602	Front chanter	1
18	Spring	SUS	320110104	Front/rear rotor	5
19	Vane	Resin board	VP2120: 320100101	Front rotor	2
			VP2220: 320100301	Front rotor	2
20	Valve	SUS	320240101	Rear chanter	1
21	Spring	SUS	310080301	Rear chanter	1
22	Valve	FKM	311150103	Rear chanter	1
23	Vane	Resin board	320100201	Rear rotor	2
24	washer	Paper	320200101	Outlet port	1
25	O ring	FKM	300310081	Oil-drain screw	2
26	O ring	FKM	320160101	Oil sight	1
27	Oil sight	Glass	320170101	Oil sight	1
28	washer	FKM	320190101	Oil sight	1
29	O ring	FKM	KF25:300310070	Outlet port	1

Chart 4 Spare parts list

1. Please refer to the exploding drawing for the relationships of each spare part.

★ We reserve the right to modify the design and specified date including operating manual of the pump. Without notice.

Correct Disposal of this product:

This marking indicates that this product should not be disposed with other household wastes. To prevent possible harm to the environment or human health from uncontrolled waste disposal, please use the return and collection systems or contact the retailer where the product was purchased. They can take this product for environmental safe recycling.



9.2 易损件一览表

序号	品名	材料	代码	使用位置	数量
			VP2100、VP2200		
1	电机纸垫	纸板	320220101	电机	1
2	弹性联轴器	橡胶	320050101 (三相)	联轴器	1
			320050102 (单相)		
3	油封	FKM	300281601	油泵盖	1
4	O型圈	FKM	300310072	前定子	1
5	O型圈	FKM	300310137	前转子	1
6	弹簧	SUS	320110205	支架	1
7	O型圈	FKM	300310074	防返流阀盖	1
8	油封	FKM	300280902	防返流阀盖	1
9	防返流阀板	FKM	320510101	防返流活塞	1
10	O型圈	FKM	300310073	进气嘴	1
11	控制阀总成	/	320990101	进气嘴	1
12	真空表	/	310500601	/	1
13	弹簧	SUS	320110302	气镇	1
14	前端密封垫	FKM	320230101	气镇	1
15	油箱O型圈	FKM	300310079	支架	1
16	前端密封垫	无石棉板	320210101	前定子	1
17	油封	FKM	300280602	前定子	1
18	旋片弹簧	SUS	320110104	前后转子	5
19	前旋片	树脂板	VP2120: 320100101	前转子	2
			VP2220: 320100301	前转子	2
20	排气阀片	SUS	320240101	后定子	1
21	弹簧	SUS	310080301	后定子	1
22	气镇阀头	FKM	311150103	后定子	1
23	后旋片	树脂板	320100201	后转子	2
24	排气口纸垫	无石棉板	320200101	排气嘴	1
25	O型圈	FKM	300310081	注/放油塞	2
26	油镜密封圈	FKM	320160101	油镜	1
27	油镜	玻璃	320170101	油镜	1
28	油镜垫	FKM	320190101	油镜	1
29	O型圈	FKM	KF25:300310070	排气嘴	1

表4 易损件一览表

注：1、零件间的相互关系请参照分解图。

★ 我们保留本说明书中设计与数据的修改权，如果更改恕不另外通知。

该产品的正确处置方式

此标记表明该产品不应与其他家庭废物一起处理。为防止不受控制的废物处理可能对环境或人类健康造成危害，请使用返回和收集系统或联系购买产品的零售商。他们可以把这个产品进行环保安全的回收。

