



Making Your Job More Enjoyable

Recovery Unit User Manual

VRR12L/VRR24L

VRR12L-OS/VRR24L-OS



VALUE Mechanical & Electrical Products CO., LTD

Add: No. 5 Third Street, East Industrial Park, Wenling, Zhejiang, China

Tel:+86-576-86191959

Fax:+86-576-86191957

Email: value@worldvalue.cn

www.worldvalue.cn



VALUE • Quality Assurance

TABLE OF CONTENT

General Safety.....	1
Operation Manual	3
Specification.....	5
Introduction of OperationPanel	6
Parts Diagram.....	7
Wiring Diagram.....	8
VRR12L Operating Instruction	
1). Refrigerant Hoses Exhaust	9
2). Recovery Method.....	10
3). Self-purge Method.....	11
4). Liquid Push/Pull Method.....	12
VRR24L Operating Instruction	
1). Refrigerant Hoses Exhaust	13
2). Recovery Method.....	14
3). Self-purge Method.....	15
4). Liquid Push/Pull Method.....	16
Trouble Shooting.....	17

GENERAL SAFETY

Use information

- In order to prolong the usage of the recovery unit, please read the manual carefully before using, which can help you to fully understand the safety, specification as well as operating procedure of the recovery unit.
- Please check the product received is same as you ordered.
Please check the product if there is any damage during transportation.
Contact with local distributor if the above problem is found.
- Please read the manual carefully and use the unit according to the product operating procedures.

Safety indication

Warning

Indicates procedures that must be strictly observed to prevent hazards to persons.

Notice

Indicates procedures must be strictly observed to prevent damage or destruction of the unit.

Matters needing attention

Warning

This appliance is not intended for use by persons (including children) with reduced physical, sensory or mental capabilities, or lack of experience and knowledge, unless they have been given supervision or instruction concerning use of the appliance by a person responsible for their safety.

Children should be supervised to ensure that they do not play with the appliance.

If the supply cord is damaged, it must be replaced by a special cord or assembly available from the manufacturer or its service agent.

Only a qualified technician can operate this recovery unit.

Before starting the equipment, make sure that it is well grounded.

While using electrical wire, the wire must be well connected and grounded.

Only a qualified electrician can do the wire connection according to the technical standard and circuit diagram.

Be sure the power is off before examining or repairing the recovery unit.

GENERAL SAFETY

When the unit breaks down, be sure the power is off before you do any operation.

Please take power supply and the capacity of your ammeter and electrical wire.

Only authorized refillable refrigerant tanks can be used. It requires the use of recovery tanks with a minimum working pressure of 45 bar(652.6 psi). Do not overfill the recovery tank, maximum at 80% capacity to make sure that there is enough space for liquid expansion. Overfilling of the tank may cause a violent explosion.

Always wear safety goggles and protective gloves while working with refrigerants to protect your skin and eye from hurting by refrigerant gases or liquid.

Do not use this equipment near flammable liquid or gasoline.

An electric scale is needed to prevent overfilling.

Be sure that the place where you are working is thoroughly ventilated.

If the original power supply cord is damaged, choose carefully for the replacing one, or you may directly buy from us.

Notice

Be sure the unit is working under the right power supply.

When using an extension cord it should be minimum 2.0mm² AWG and no longer than 7.5 m, otherwise it may cause the voltage drop and damage the compressor.

The input pressure of the unit should not exceed 26bar (377.1psi).

The unit need to be laid in horizontally, otherwise it will lead to unexpected vibration, noise or even abrasion.

Do not expose the equipment to sun or rain.

The ventilation opening of the unit must not be blocked.

If the overload protector pops, reposition it after 5 minutes.

If this equipment is equipped with oil separator device only during vapor recovery process it will purification and recycling of the refrigerants.

When the recovery vapor over 8 kg it need to release the oil of oil separator device.
(While release oil the internal system must be without pressure)

OPERATION MANUAL

1. Do not mix different refrigerants together in one tank, or they could not be separated or used.
2. Before recovering the refrigerant, the tank should achieve the vacuum level: -75cmHg(-29.6psi), which is for purging non-condensable gases. Each tank was full of nitrogen when it was manufactured in the factory, thus the nitrogen should be evacuated before the first use.
3. The switch should be at "O" Position before operation. All the valves must be closed, the input and output fittings should be covered with protective caps when the unit is not in operation. The air moisture is harmful to the recovery result and will shorten the life span of the unit.
4. A filter drier should always be used and should be replaced frequently. And each type of refrigerant must have its own filter. For the sake of ensuring the normal operation of the unit, please use the filter specified by our company. High quality filter drier will bring high quality services.
5. Special-caution is needed when recovering from burnt system, and two dry filter is needed.
6. a. (only suitable for VRR12L)

The unit has an Internal High Pressure Shut-Off switch. If the pressure inside the system is above rated shut-off pressure (see specification), compressor will automatically shut off and the power will be off. To restart the compressor, please lower the internal pressure (Output gauge indicates lower than 30bar/435psi) and hit the Reset button, then turn on the power to restart the compressor.

- b. (only suitable for VRR24L)

The unit has an Internal High Pressure Shut-Off switch. If the pressure inside the system is above rated shut-off pressure (see specification), compressor will automatically shut off and the high pressure alarm light will turn on. To restart the compressor, please lower the internal pressure (Output gauge indicates lower than 30 bar/435.1 PSI) , after the high pressure alarm light turn off, hit the Reset button, then turn on the power to restart the compressor.

c. When high pressure protection is initiated, please find out the cause and deal with it before restarting the unit. Cause of High Pressure Protection and Trouble Shooting:

- ① The input valve of the refrigerant tank is closed--open the valve will help solve the problem.
- ② The connecting hose between the recovery unit and refrigerant tank is stuck--close all the valves and replace the connecting hose.
- ③ The temperature of the refrigerant tank is too high, pressure is too high--give it some time to cool down and the pressure will come back to normal.

OPERATION MANUAL

7. (only suitable for VRR24L)

The unit has an Internal Low Pressure Shut-Off Switch and Bypass switch;

- ① When the Bypass switch is on "Manual" position, the lower pressure switch doesn't function.
 - ② When the Bypass switch is on "Auto" position, the lower pressure switch will work. If the pressure inside the system lower than -5inHg--14inHg (-12.7cmHg--35.5cmHg)(according to model), the unit will automatically shut off and the Green Alarm Light turns on.
8. This unit can be used together with a float level sensor. Please connect the recovery unit and the tank with the 80% O.F.P. Cable. If the liquid refrigerant reaches 80% capacity of the tank the recovery unit will automatically shut off and the Red Alarm Light turns on. Before restart please change a new tank.
9. If the refrigerant tank has no float level sensor, please take the 80% O.F.P Cable off. Otherwise the recovery unit can not started. In this case, an electric scale is required to monitor the recovered refrigerant amount.
10. In order to gain maximum recover speed, a hose with inner diameter bigger than 4mm is recommended and the hose should better be shorter than 1.5m.

11. While recovering large amounts of liquid, use the Push/Pull Mode.

12. After recovering, make sure there is no refrigerant left in the unit. Read the Purge Operation carefully.

Liquid refrigerant remained in the unit may be expanded and destroy the components.

13. If the unit is to be stored or not used for any length of time, we recommend that it be completely evacuated of any residual refrigerant and purged with dry nitrogen.

14. Connection hose with check is recommended, it can prevent refrigerant lose.

15. The intake port is equipped with filter screen, please wash it frequently to keep it clean.

16. The Low Pressure Gauge shows the pressure of the intake port of the compressor and the High Pressure Gauge shows the pressure of the outlet port of the recovery unit.

17. After using , please ture the knob to "0" position.

SPECIFICATION

	VRR12L	VRR24L
Refrigerants	Category III: R12, R134a, R401C, R406A, R500 Category IV: R22, R401A, R401B, R402B, R407C, R407D, R408A, R409A, R411A, R411B, R412A, R502, R509 Category V: R402A, R404A, R407A, R407B, R410A, R507	
Power	110V~120V / 60Hz ; 220V~240V / 50~60Hz	
Motor	3/4 HP	1 HP
Motor Speed	1450 RPM@50Hz / 1750 RPM@60Hz	
Maximal Current Draw	110V: 8A; 220V:4A	110V: 10A; 220V: 5A
Compressor	Oil-less, Air-cooled, Piston	
High Pressure Protector	38.5bar/3850kPa(558psi)	
Operating Temperature	0°C ~40°C / 32~104°F	
Dimensions	400mm×250mm×355mm	
Net Weight	13.0 kg	13.5 kg

VRR12L

Refrigerants	R134a	R22	R410A
Liquid	1.60kg/min	1.80kg/min	2.20kg/min
Push/Pull	4.60kg/min	5.60kg/min	6.30kg/min

VRR24L

Refrigerants	R134a	R22	R410A
Liquid	3.00kg/min	3.50kg/min	3.50kg/min
Push/Pull	7.50kg/min	8.50kg/min	9.50kg/min

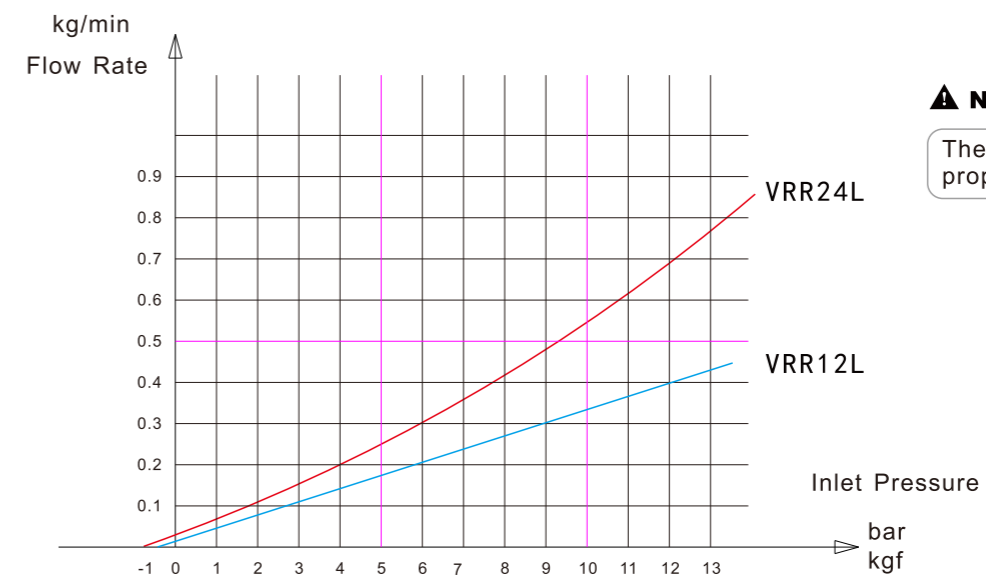

▲ Notice

The flow rate of vapor is direct proportion to inlet pressure.

INTRODUCTION OF OPERATION PANEL

VRR12L

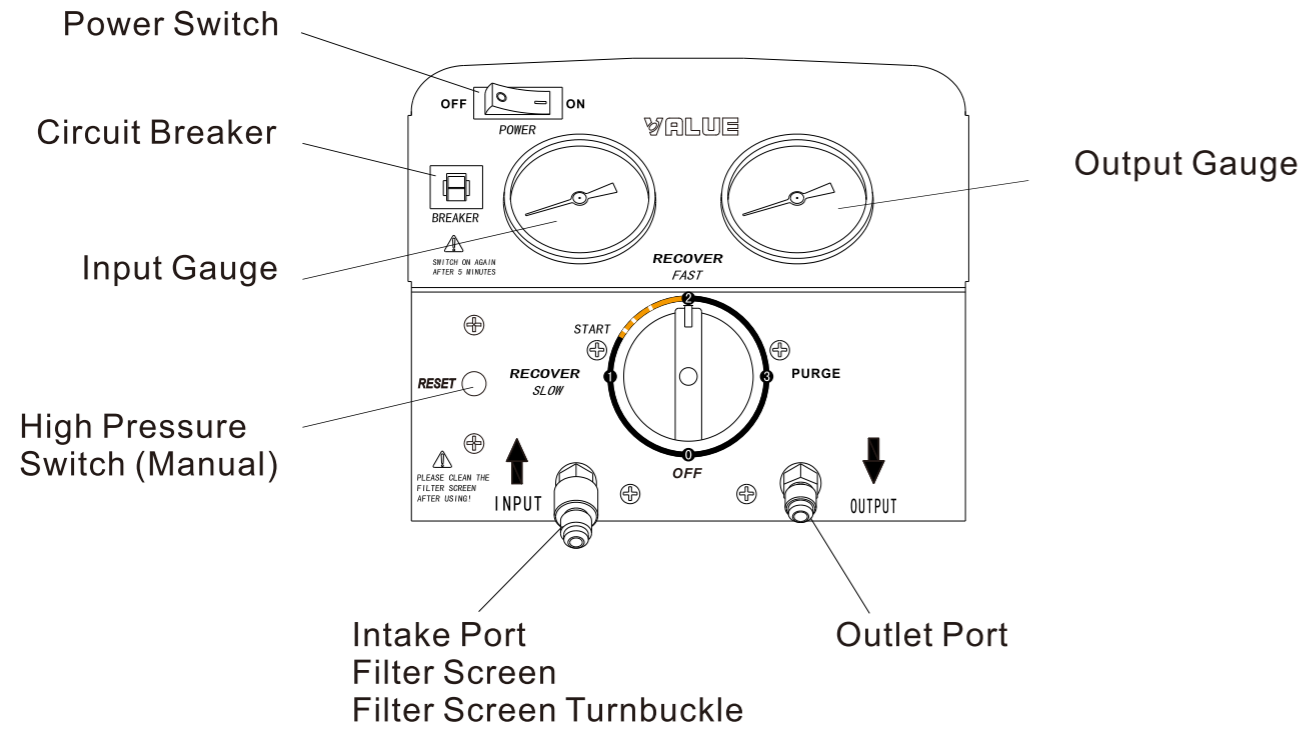

VRR24L

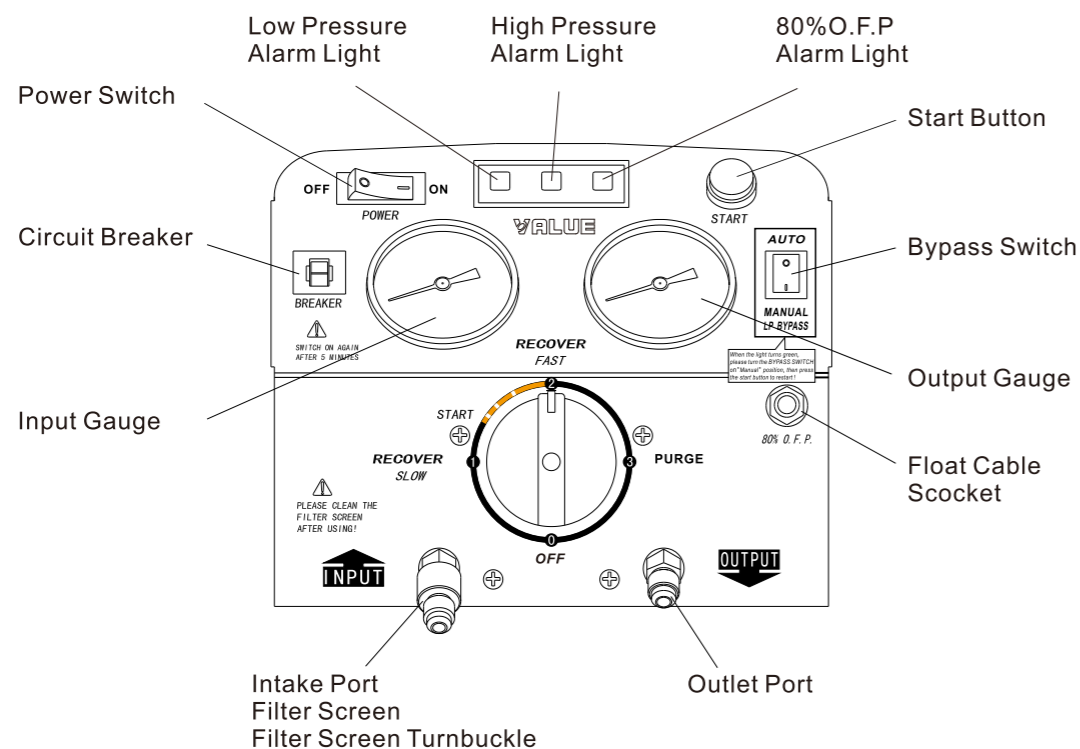

PARTS DIAGRAM

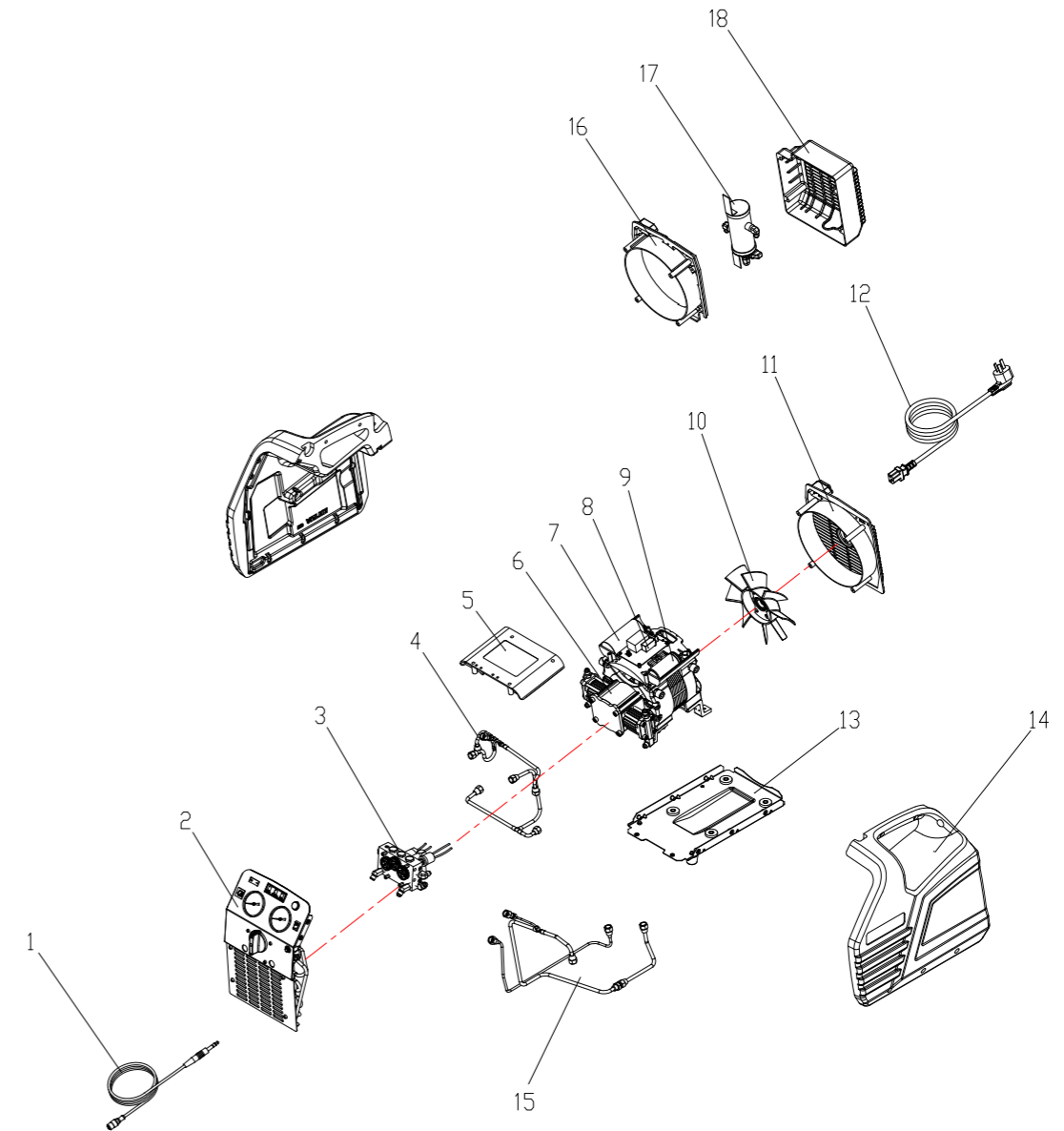

NO.	Component	NO.	Component
1	O.F.P. Cable	10	Fan
2	Front Panel	11	Fan Cover
3	Control Valve	12	Power Supply Cord
4	Copper Pipes	13	Base
5	Junction Box Cover	14	Cover
6	Compressor	15	Copper
7	Running Capacitor	16	PipesOil Separator Fan
8	Circuit Board	17	Oil Separator
9	Starting Capacitor	18	Oil Separator Back Cover

■: VRR24L Designed With

▲: Oil Separator Designed With

WIRING DIAGRAM

VRR12L

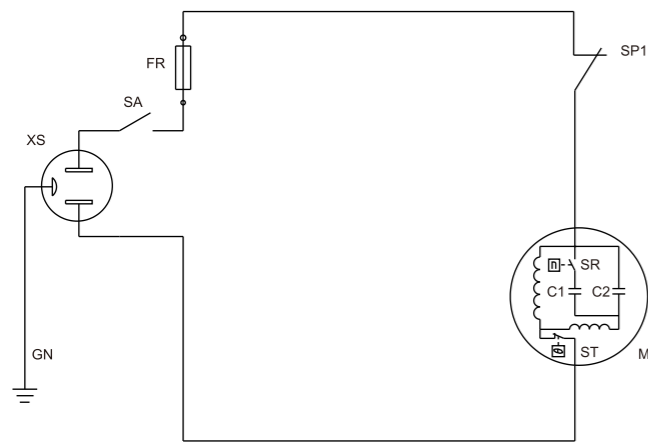

NO.	Graphics Code	Component
1	XS	Power Outlet
2	SA	Power Switches
3	FR	Overload Protection Device
4	Sp1	High Pressure Switchgear
5	M1	Compressor Motor

VRR24L

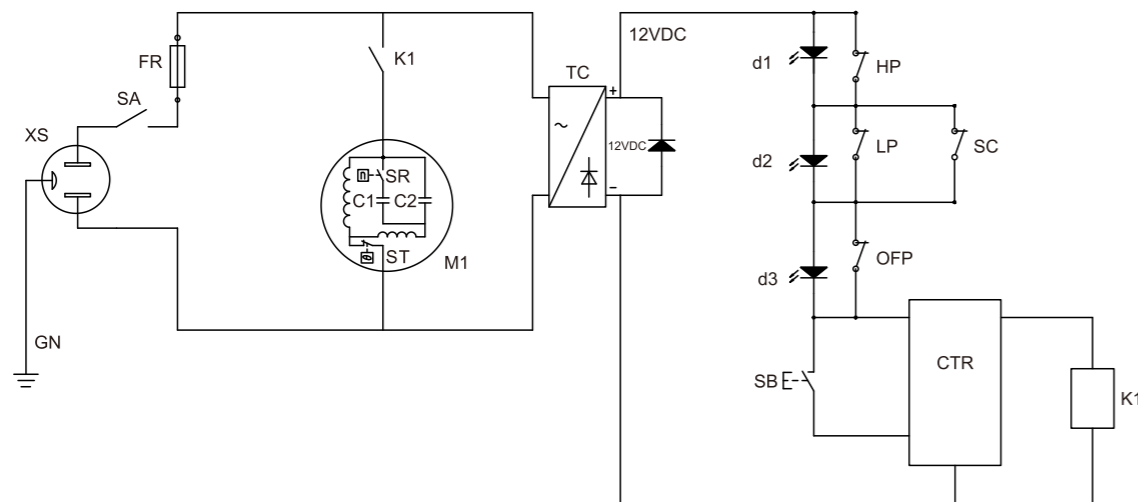

NO.	Graphics Code	Component	NO.	Graphics Code	Component
1	XS	Power Outlet	10	HP	High Pressure Switch
2	SA	Power Switches	11	LP	Low Pressure Switch
3	FR	Overload Protection Device	12	OFP	80%O.F.P. Switch
4	M1	Compressor Motor	13	d1、d3	Red Indicator
5	SR	Centrifugal Switch	14	d2	Green Indicator
6	C1	Start Capacitor	15	SC	Option Switch
7	C2	Running Capacitor	16	SB	Start Button
8	ST	Motor Thermal Protectors	17	CTR	Control Module
9	TC	Electronic Transformer	18	K1	Relay

VRR12L OPERATING INSTRUCTION

1). Refrigerant pipes' exhaust

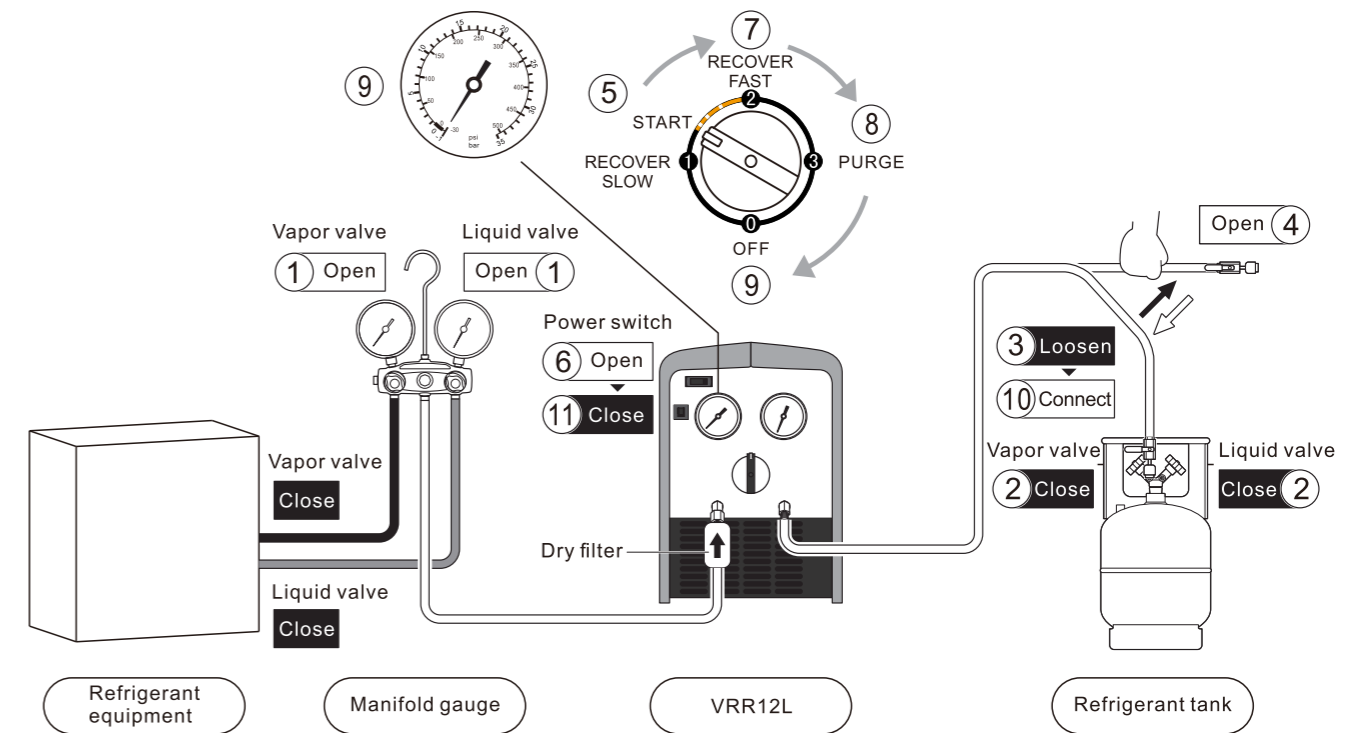

Ready for operation

※ Connect the pipes correctly and firmly.

(Please refer to the connection diagram)

1. Open the vapor and liquid valves of manifold gauge.
2. Close the vapor and liquid valves of tank.
3. Loosen the connecting pipes of refrigerant tank.
4. Open the valve of pipes.

Start operation

5. Turn the switch to position "START".
6. Turn on the power switch.
7. Turn the switch to position "2" and start exhausting the air of inside pipes.
8. While the input gauge getting to -1 bar, turn the switch to position "3" to start self-purge.

9. While the input gauge getting to -1bar again, turn the switch to position "O" to finish self-purge.
10. Connect the pipes to refrigerant tank.

Finish operation

11. Turn off the power switch.

VRR12L OPERATING INSTRUCTION

2). Recovery mode

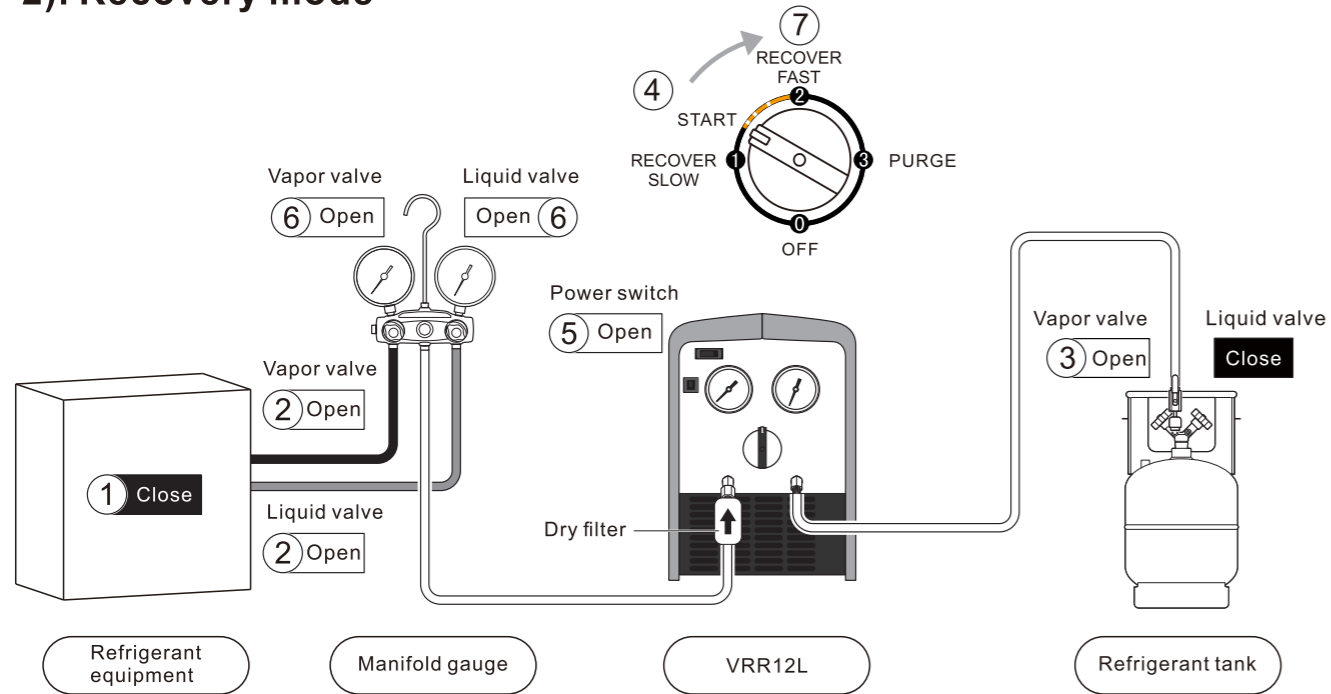

Ready for operation

※ Connect the pipes correctly and firmly.
(Please refer to the connection diagram)

※ Make sure all valves are closed.

1. Switch off the power of refrigerant equipment.
2. Open the vapor and liquid valves of refrigerant equipment.
3. Open the vapor valve of the refrigerant tank.

Start operation

4. Turn the switch to the position "START".
5. Turn on the power switch.
6. a. Open the liquid valve for liquid recovery.
b. Open the vapor valve for vapor recovery.
7. Turn the switch slowly to position "2" for faster recovery.
8. When the recovery is finished, the unit gets the needed vacuum or automatically stop with low pressure protection.

※ There is no need to turn off the power and it can do the self-purge work directly.

▲ Notice

- ① If compressor impact occurs at the position "2", turn the switch to position "START" until the impact stops.
- ② If the recovery restarts after interruption of power or difficult to start,
 - a. Turn the switch to position "START", turn on the power switch, press start button.

▲ Notice

- ① Turning the switch to position "1" gets a stable recovery of liquid with low speed of 1Kg/Min.
- ② If compressor impact occurs at the position "1", turn the switch slowly to position "START" until the impact stops. Make sure the pressure is not at 0, because it doesn't work at 0.

VRR12L OPERATING INSTRUCTION

3). Self-purge mode

▲ Notice

The unit must be purged after each use;
Liquid refrigerant remained may expand and damage the components and pollute the environment.

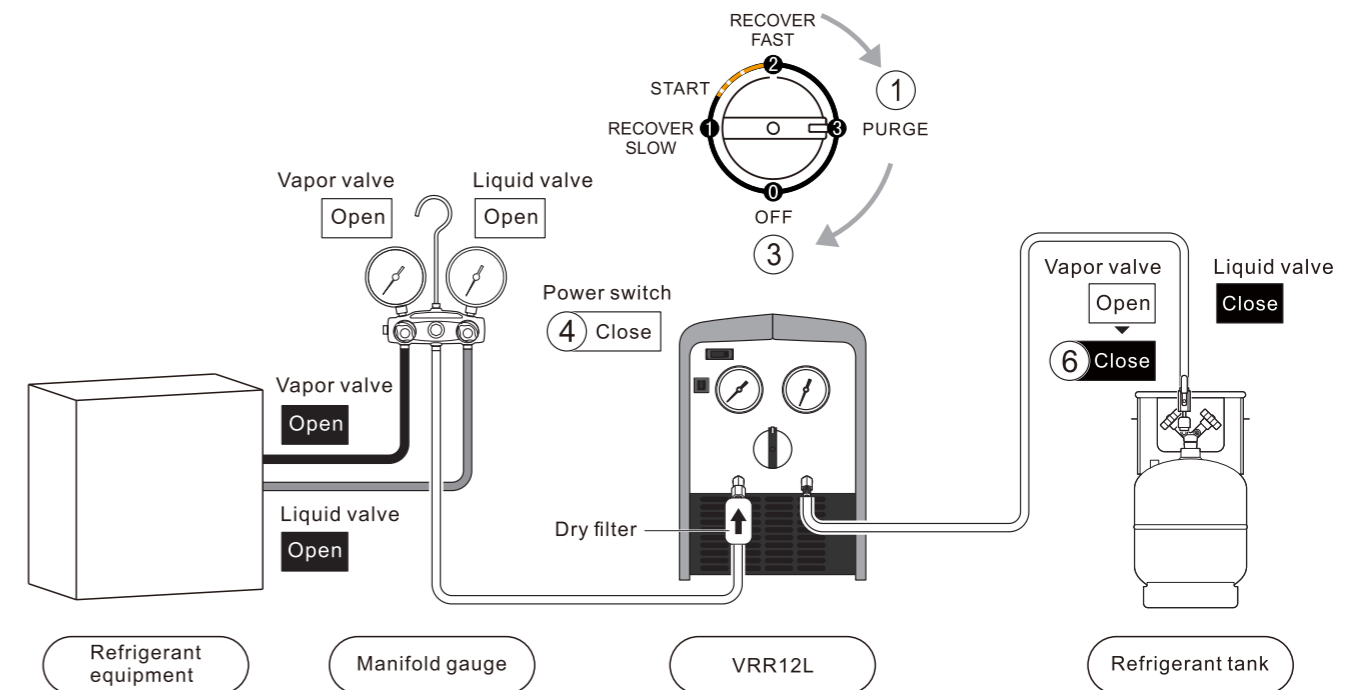

Ready for operation

1. Turn the switch to position "3" to start purge.
2. When the self purging is finished, the unit gets needed vacuum.

Finish operation

3. Turn the switch to position "0".
4. Turn off the power switch.
5. Close the valve of pipes.
6. Turn off the vapor valve of refrigerant tank.

VRR12L OPERATING INSTRUCTION

4). Liquid push/pull mode

▲ Notice

An electric scale is needed to monitor the recover process to prevent overfilling.

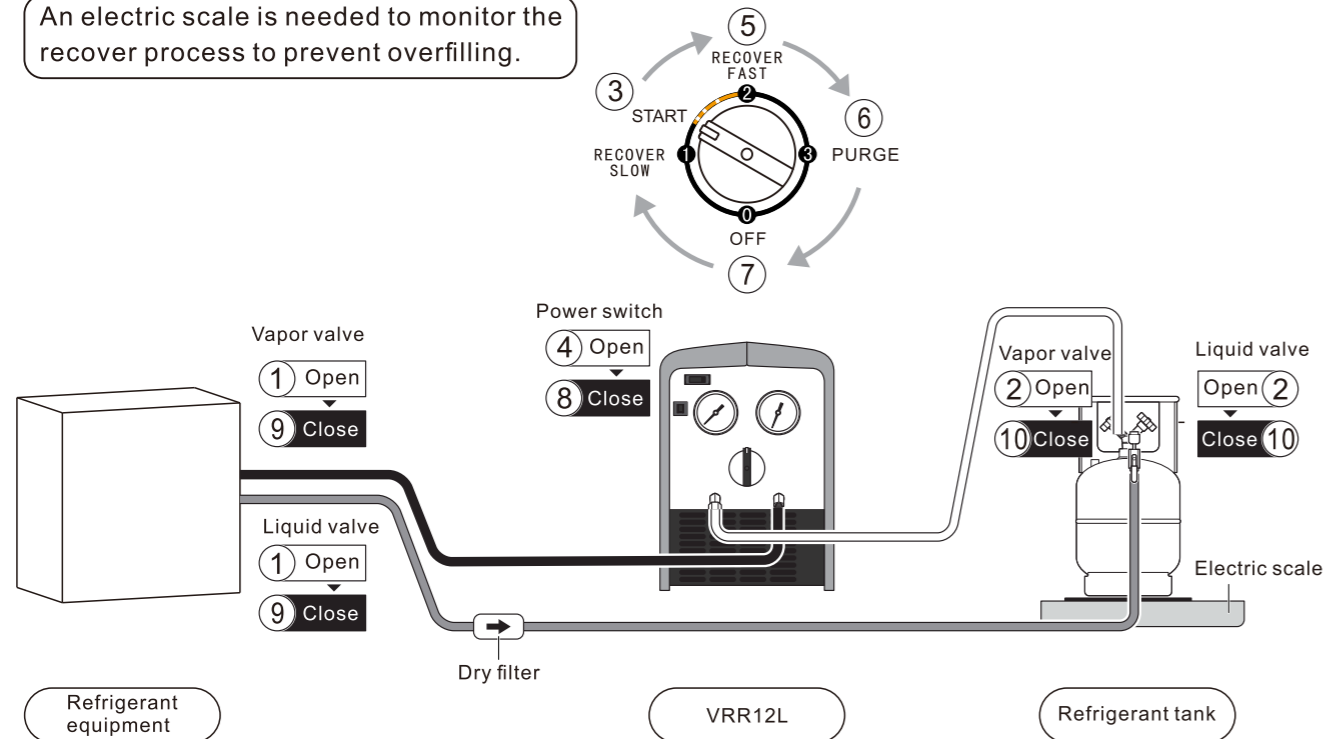

Ready for operation

- ※ Connect the pipes correctly and firmly.
(Please refer to the connection diagram)
- ※ Make sure all valves are closed.

Start operation

1. Open the vapor and liquid valves of refrigerant equipment.
2. Open the vapor and liquid valves of the refrigerant tank.
3. Turn the switch to position "START".
4. Turn on the power switch.
5. Turn the switch to position "2" to start push/pull mode.

※ When the display of electric scale remains unchanged or changes very slowly, it means the liquid recovery is finished, and it is time for vapor recovery.

6. Turn the switch to position "PURGE" and follow self-purge mode to purge the gas refrigerant.
7. Turn the switch to position "OFF"
8. Turn off the power switch.
9. Close the vapor and liquid valves of refrigerant equipment.
10. Close the vapor and liquid valves of refrigerant tank.
11. Connect the pipes again and recover the vapor of refrigerant equipment according to recovery mode.

Finish operation

VRR24L OPERATING INSTRUCTION

1). Refrigerant pipes' exhaust

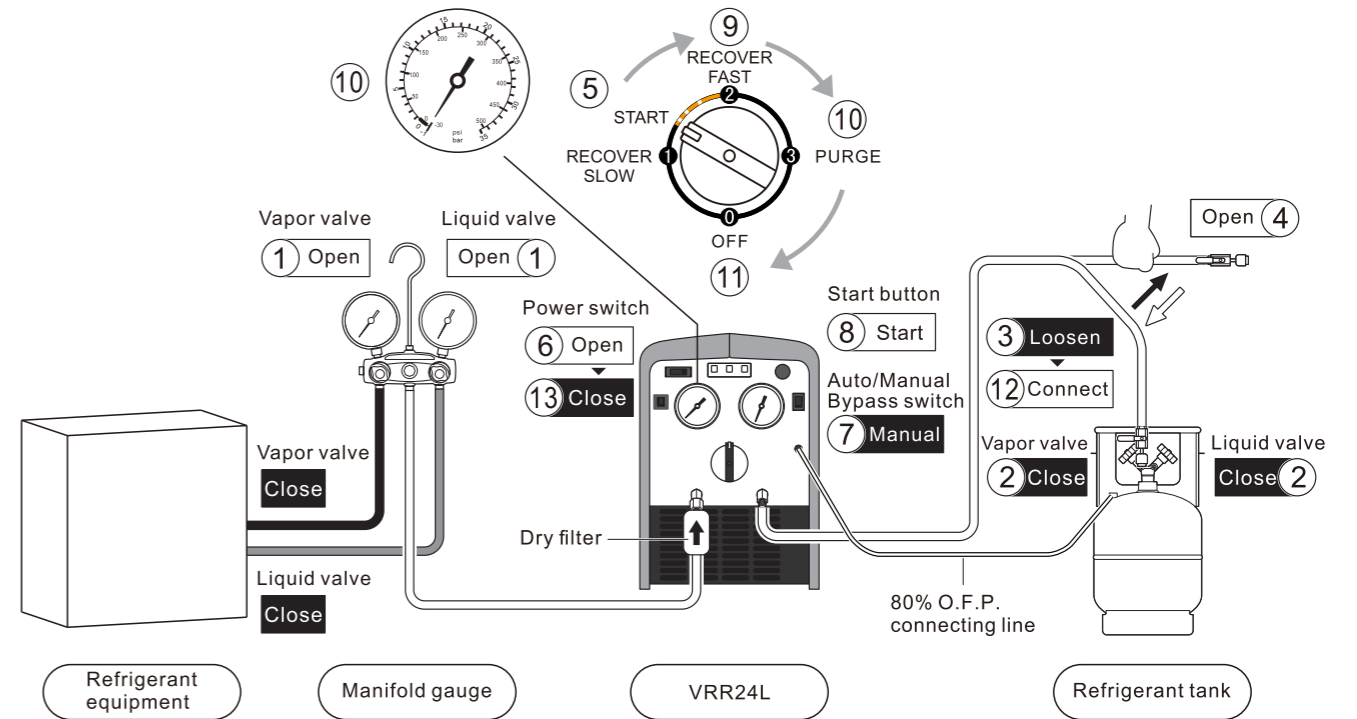

Ready for operation

- ※ Connect the pipes correctly and firmly.
(Please refer to the connection diagram)

1. Open the vapor and liquid valves of manifold gauge.
2. Close the vapor and liquid valves of tank.
3. Loosen the connecting pipes of refrigerant tank.
4. Open the valve of pipes.

Start operation

5. Turn the switch to position "START".
6. Turn on the power switch.
7. Turn the bypass switch to position "MANUAL".
8. Press start button.
9. Turn the switch to position "2" and start exhausting the air of inside pipes.

10. While the input gauge getting to -1bar ,turn the switch to position "3" to start self-purge.
11. While the input gauge getting to -1bar again, turn the switch to position "O" to finish self-purge.
12. Connect the pipes to refrigerant tank.

Finish operation

13. Turn off the power switch.

VRR24L OPERATING INSTRUCTION

2). Recovery mode

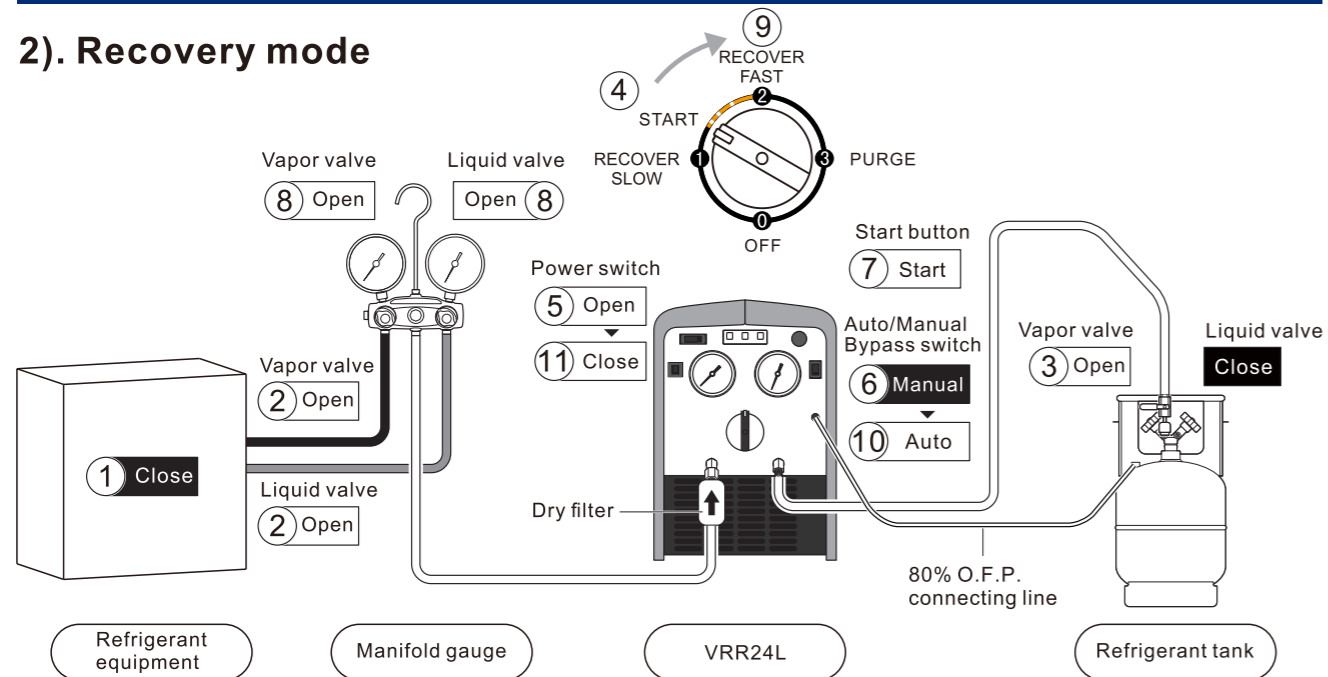

Ready for operation

※ Connect the pipes correctly and firmly.
(Please refer to the connection diagram)

※ Make sure all valves are closed.

1. Switch off the power of refrigerant equipment.
2. Open the vapor and liquid valves of refrigerant equipment.
3. Open the vapor valve of the refrigerant tank.

Start operation

4. Turn the switch to the position "START".
5. Turn on the power switch.
6. Turn the bypass switch to position "MANUAL".
7. Press start button.
8. a. Open the liquid valve for liquid recovery.
b. Open the vapor valve for vapor recovery.
9. Turn the switch slowly to position "2" for faster recovery.
10. When the recovery is finished, the unit gets the needed vacuum or automatically stop with low pressure protection.

⚠ Notice

- ① If compressor impact occurs at the position "2", turn the switch to position "START" until the impact stops.
- ② If the recovery restarts after interruption of power or difficult to start,
 - a. Turn the switch to position "START", turn on the power switch, press start button.

⚠ Notice

- ① Turning the switch to position "1" gets a stable recovery of liquid with low speed of 1.2Kg/Min.
- ② If compressor impact occurs at the position "1", turn the switch slowly to position "START" until the impact stops. Make sure the pressure is not at 0, because it doesn't work at 0.

11. Turn the bypass switch to position "AUTO" and the recovery will stop automatically when finish recovery.

※ There is no need to turn off the power and it can do the self-purge work directly.

VRR24L OPERATING INSTRUCTION

3). Self-purge mode

⚠ Notice

The unit must be purged after each use;
Liquid refrigerant remained may expand and damage the components and pollute the environment.

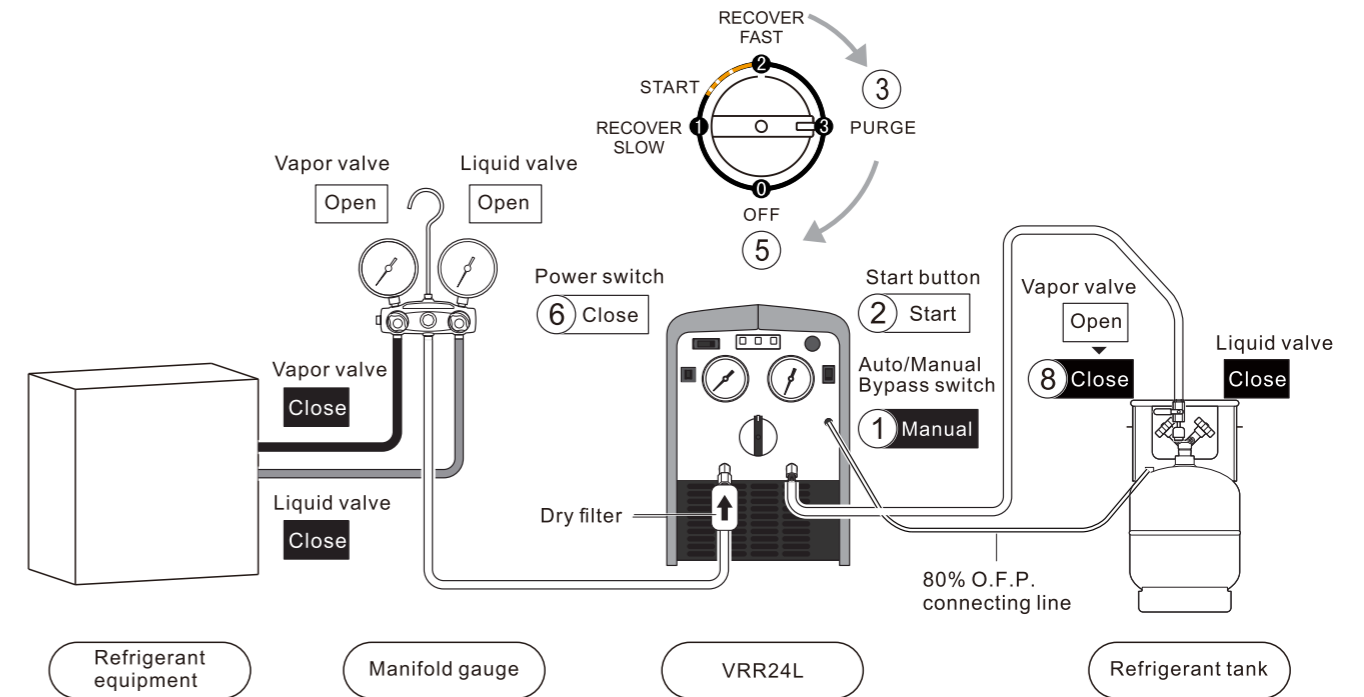

Ready for operation

1. The unit stops automatically when finish recovery,
Turn the bypass switch to position "MANUAL".
2. Press start button.
3. Turn the switch to position "3" to start purge.
4. When the self purging is finished, the unit gets needed vacuum.

Finish operation

5. Turn the switch to position "0".
6. Turn off the power switch.
7. Close the valve of pipes.
8. Turn off the vapor valve of refrigerant tank.

VRR24L OPERATING INSTRUCTION

4). Liquid push/pull mode

▲ Notice

An electric scale is needed to monitor the recover process to prevent overfilling.

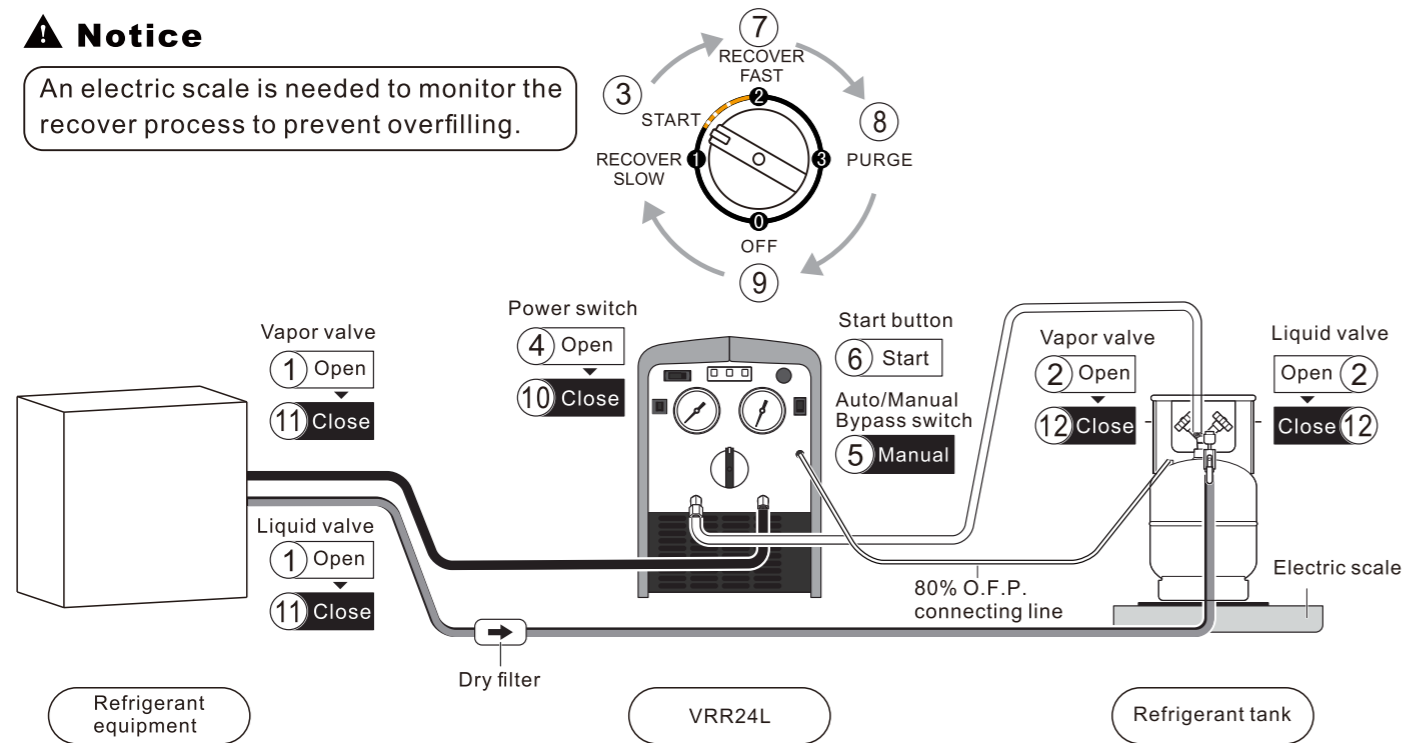

Ready for operation

- ※Connect the pipes correctly and firmly.
(Please refer to the connection diagram)
- ※Make sure all valves are closed.

Start operation

1. Open the vapor and liquid valves of refrigerant equipment.
2. Open the vapor and liquid valves of the refrigerant tank.
3. Turn the switch to position "START"
4. Turn on the power switch.
5. Turn the bypass switch to position "MANUAL".
6. Press start button.
7. Turn the switch to position "2" to start push/pull mode.

※ When the display of electric scale remains unchanged or changes very slowly, it means the liquid recovery is finished, and it is time for vapor recovery.

8. Turn the switch to position "PURGE" and follow self-purge mode to purge the gas refrigerant.
9. Turn the switch to position "OFF"
10. Turn off the power switch.
11. Close the vapor and liquid valves of refrigerant equipment.
12. Close the vapor and liquid valves of refrigerant tank.
13. Connect the pipes again and recover the vapor of refrigerant equipment according to recovery mode.

Finish operation

▲ Warning

When the showing of the electric scale show that the refrigerant in the tank reaches 80% capacity, please turn the power off and close the valves of the tank.

TROUBLE SHOOTING

FAULT	CAUSE	SOLUTION
FAN no response	Mechanical damage	1. Replace the fan 2. Factory service required
Compressor not start (Jammed)	1. External pressure is too high 2. Motor failure or other components damaged	1. a. When recover the liquid, turn the knob to "START" position, then restart b. When recover the vapor, turn the knob to "PURGE" / "3" position, then restart 2. a. Replace the components b. Factory service is needed
Press the power switch but compressor no response	1. (only suitable for VRR12L) Shut off by high pressure protection 2. (only suitable for VRR24L) a. Shut off by high pressure protection, red alarm light turns on. b. Low pressure protection, green alarm light turns on (recovery not finished) c. 80% O.F.P. cable not well connected with tank. 3. Internal wiring fault.	1. (only suitable for VRR12L) a. Lower the pressure of the unit b. Press high pressure button to reset 2. (only suitable for VRR24L) a. Lower the pressure of the unit b. Check if the hoses are well connected c. Check the connection. 3. a. Be checked by qualified technician b. Factory service required
Compressor start but stops within a few minutes	1. High pressure shut off due to wrong operation, such as: Outlet valve not open, Refrigerant tank valve not open 2. Motor thermal protector shuts off 3. Circuit breaker shuts off 4. (only suitable for VRR24L) a. 80% over filling protection, red alarm light turns on b. Recovery is over and the unit is under low pressure protection, green alarm light turns light c. Overload during liquid recovery, red alarm light goes out after a flash	1. Read carefully the Operation Manual and follow the instructions while operating 2. The compressor will restart automatically after a few minutes 3. Cooling the Circuit breaker down and press "circuit breaker" to restart after 5 minutes 4. (only suitable for VRR24L) a. Replace with an empty recovery tank b. Refer to step of self-purge method c. Turn the knob to "START" position, then restart
Low recovery speed	1. The pressure of the refrigerant tank is too high 2. Piston ring of the compressor is damaged	1. Cool the tank down can help bringing down the pressure 2. a. Replace the components b. Factory service required
Unit doesn't pull out a vacuum	1. Connecting hoses are loose 2. Leakage in the unit	1. Tighten the hose connections 2. a. Replace the components. b. Factory service required

Correct Disposal of this product:

This marking indicates that this product should not be disposed with other household wastes throughout the EU. To prevent possible harm to the environment or human health from uncontrolled waste disposal, recycle it responsibly to promote the sustainable reuse of material resources. To return your used device, please use the return and collection systems or contact the retailer where the product was purchased. They can take this product for environmental safe recycling

